

Dash Camera User's Manual













Foreword

Model

CDR8213 Series

Safety Instructions

The following categorized signal words with defined meaning might appear in the manual.

Signal Words	Description
 DANGER	Indicates a high potential hazard which, if not avoided, will result in death or serious injury.
 WARNING	Indicates a medium or low potential hazard which, if not avoided, could result in slight or moderate injury.
 CAUTION	Indicates a potential risk which, if not avoided, may result in property damage, data loss, lower performance, or unpredictable result.
 ESD	Indicates electrostatic sensitive devices.
 ELECTRIC SHOCK	Indicates the danger of high voltage.
 LASER RADIATION	Indicates a laser radiation hazard.
 MOVING FAN BLADES	Indicates dangerous moving parts. Keep away from rotating fan blades.
 MECHANICAL INJURY	Indicates mechanical injuries caused by device parts.
 TIPS	Provides methods to help you solve a problem or save your time.
 NOTE	Provides additional information as the emphasis and supplement to the text.

Terms

To simplify descriptions, some frequently cited functions and names in this manual have the following meanings:

- Unless otherwise specified, “device” in this document refers to “dash camera”
- To keep the devices safe, IP addresses, MAC addresses, and serial numbers cited in this manual have all been modified.

Revision History

Version	Revision Content	Release Time
V1.0.2	Modify camera installation and AI configuration.	2022.10
V1.0.1	Modify the product name.	2022.04
V1.0.0	First release.	2021.09

Important Safeguards and Warnings

This section introduces the proper way of using the device, and danger and property damage preventions. Before using the device, read this manual carefully. Follow the instructions and keep this manual properly for future reference.

Operating Requirements

- Do not place the device in a place exposed to sunlight or near the heat source.
- Keep the device away from dampness, dust, or soot.
- Keep the device on a stable place to prevent it from falling.
- Do not drop or splash liquid onto the device, and make sure that there is no object filled with liquid on the device to prevent liquid from flowing into it.
- Prevent foreign objects from entering the device, which might result in damage.
- Put the device in a well-ventilated place, and do not block the ventilation of it.
- Use the device within the rated range of power input and output.
- Do not disassemble the device.
- Transport, use, and store the device under the allowed humidity and temperature conditions.
- Do not expose the device to water or excessive moisture when washing the car. A failure to follow this instruction might result in short circuit, fire, or other malfunctions.
- The dust on the circuit board will cause short circuit, which affect the normal operation of the device and even damage the device. To make the device work stably for a long time, please regularly use the brush to remove the dust from components, including circuit board, connectors, and chassis.
- Keep the device installed horizontally and make sure the internal anti-vibration components work properly.
- After all the cables are connected, tie up the cables to avoid the dangers such as short circuit, heat and electric shock resulted from loose cables.
- Pay attention to grounding of camera, since poor grounding might lead to chip damage.

Power Supply Requirements

- Use locally recommended power cord in the limit of rated specifications.
- The appliance coupler is a disconnection device. Keep a convenient angle when using it.
- Take care to complete the circuit connection. A failure to follow this instruction might result in device damage.
- Prevent short circuit from occurring on all external wiring parts.
- After all the lines connections are completed, you can start connecting power cable.
- Ensure the project is well grounded to avoid interference to video and audio signals and avoid electrostatic or induced voltage to damage the device.
- Please unplug the power cable before you remove the audio/video signal cable or RS-232; otherwise these ports might be damaged.

Contents

Foreword	I
Important Safeguards and Warnings	II
1 Product Introduction	5
1.1 Overview	5
1.2 Functions.....	5
2 Installation	7
2.1 Unpack and Check.....	7
2.2 Device Structure.....	7
2.2.1 Top Cover	7
2.2.2 Side Panel Ports	8
2.2.3 Port Definition.....	10
2.2.4 Dimension	11
2.3 Device Installation	11
2.3.1 Installing SIM Card and TF card.....	12
2.3.2 Installing Camera	12
2.3.3 Adjusting Angle.....	13
2.4 Cable Connection	14
2.4.1 Connecting Power Cable.....	14
2.4.2 Alarm Input Connection.....	16
2.4.3 Cable Layout	18
3 Basic Configuration	19
3.1 Starting Device.....	19
3.2 Initializing Device.....	19
3.3 Logging in to Device.....	21
3.4 Configuring IP Address	24
3.5 Configuring General Settings.....	25
3.5.1 General Settings.....	26
3.5.2 Date&Time.....	26
3.6 Configuring Record Mode	28
3.7 Configuring Storage Plan.....	29
3.7.1 Record Schedule	29
3.7.2 Snapshot Schedule	31
4 Function Operations	34
4.1 Live	34
4.1.1 Real-time Monitoring Channels	35
4.2 Video Playback	36
4.2.1 Playback operations.....	36
4.2.2 Control bar.....	37
4.2.3 Playing Back Record Video Files	38
4.2.4 Clipping Recording File	39
4.3 Alarm Info	40
5 System Settings	42
5.1 Configuring Alarm Events.....	42
5.1.1 Video Detection.....	42
5.1.2 Alarm Input	46
5.1.3 Exception	47
5.2 Configuring AI Plan	49
5.2.1 Configuring ADAS.....	50
5.2.2 Configuring DSM.....	52
5.2.3 Configuring Reminds of the Back Row	57
5.2.4 AI Search.....	58
5.3 File Backup.....	58
5.4 Configuring Camera Parameters	60
5.4.1 Configuring Image Properties.....	60

5.4.2 Encode Parameters	61
5.5 Configuring Network Parameters	66
5.5.1 Ports	66
5.5.2 Wireless Network.....	68
5.5.3 3G/4G	71
5.5.4 Email	73
5.5.5 Register	75
5.5.6 P2P	76
5.6 Managing Storage Device	77
5.6.1 Basic	77
5.6.2 Disk Manager.....	78
5.6.3 FTP	78
5.7 Configuring System.....	80
5.7.1 Configuring Serial Port Parameters.....	80
5.7.2 Managing Security	81
5.7.3 Configuring Vehicle Info.....	82
5.8 Managing User Account	85
5.8.1 Managing User.....	86
5.8.2 Managing Group.....	88
5.8.3 Resetting Password.....	89
6 Update.....	92
6.1 System Version	92
6.2 Update.....	92
7 System Maintenance	94
7.1 Requirement for Maintenance	94
7.2 System Information.....	94
7.2.1 Log.....	94
7.2.2 Network Info	95
7.2.3 Disk.....	95
7.2.4 Channel Info.....	95
7.2.5 Satellite Info	96
7.3 Automatic Maintenance	97
7.3.1 Auto Reboot.....	97
7.3.2 Auto Boot up	97
7.3.3 Auto Shutdown System.....	98
7.3.4 Acc Delay.....	98
7.4 Backup and Restore.....	98
7.4.1 Backing up Configurations.....	99
7.4.2 Importing Configurations.....	99
7.4.3 Restoring to Default.....	100
7.5 Network Sniffer	101
8 Logging in to the Device from DSS.....	103
Appendix 1 FAQ	104
Appendix 2 Storage Capacity Calculation	107
Appendix 3 Cybersecurity Recommendations	108

1 Product Introduction

1.1 Overview

Developed on the new-generation platform, the dash camera is a mobile video monitoring product that integrate video capturing, locating, drive recording and intelligent analysis functions.

Features:

- Up to 3 HDCVI video input channels and 1 built-in ADAS video input channel.
- The use of H.264/H.265 encoding ensures high encoding efficiency and saves storage space.
- The needs of using the mobile products in different networks are taken into full consideration in product design and 3G/4G modules or Wi-Fi modules are available.
- The use of professional in-vehicle design in standard size features low power consumption and novel shape.
- Unique TF card storage design makes recording backup and management easier.

This product can be widely used for in-vehicle monitoring in public transportation, long-range passenger transport, police patrol, urban management patrol, cash carriers, hazardous goods transport, and logistics transport, or video monitoring in harsh environment.

1.2 Functions

Table 1-1 Function description

Functions	Description
Storage	Stores the data in the dedicated format which cannot be falsified to ensure the data security.
Dual Stream	To cope with the low-bandwidth and instability of wireless network, the device adopts the dual-stream technology (encode real-time video and the video in network transmission separately) to optimize the encoding of network transmission, which improves the control capability of wireless network transmission.
Video Playback	<ul style="list-style-type: none">● Every channel takes recording in real time and independently, and you can play backward, monitor through network, search and download recordings.● Supports several playback modes: Slow playback, fast playback, backward playback, and frame-by-frame playback.● Displays the accurate time when the event occurred during playback.
Backup	<ul style="list-style-type: none">● Plug in a USB storage device (such as USB and mobile HDD) to back up the data.● You can back up the data by downloading the files from the memory disk of the device (such as TF card and USB flash drive) through the network.

Functions	Description
Alarm Linkage	<ul style="list-style-type: none"> ● Provides 3-channel electric level alarm inputs that can connect to signals such as car door signal, cornering lamp signal, reversing and braking signal, to give an indication and take a record. ● Protective circuit for alarm input ports to prevent device from damage.
Rollover and Collision Detection	Provides rollover and collision detection and timely releases alarms through the platform.
Operation through Network	Supports remote operations through network, such as real-time remote monitoring, video recording search and playback, and PTZ remote control.
3G/4G, Wi-Fi	Adopts the latest wireless communication technology, which has improved the manageability of the device.
Communication Interface	<ul style="list-style-type: none"> ● Offers RS-232 port to connect with external in-vehicle display. ● 1 Micro-USB port supports remote network access through connecting to Ethernet port.
Compression	Supports multi-channel audio and video signals, and each channel signal supports real-time compression by independent hardware to realize the sync between sound and image.
Satellite Positioning	Positioning history and recording linkage are available. Recording search can be linked with vehicle moving track.

2 Installation

This chapter introduces how to install the hardware of the device. Before installation, you need to know the device information, such as top cover, side, dimensions, and ports. After obtaining a sufficient understanding, you can install the SIM card, TF card and fix the device as needed.

2.1 Unpack and Check

When you receive the device, unpack the box for checks.

Firstly, check if there is any damage on the device appearance (although the packing materials are specially selected for protecting the device from most of accidental hit during transportation). Secondly, open the accessory box to check if the accessories are complete against the packing list.

Instructions about labels:

The labels on the device are very important for our after-sales service. To ensure the after-sales service, **keep the labels well, and do not tear or throw away**. You need to provide the serial number of the product when calling the after-sales service.



For tools or accessories not mentioned in the box, please purchase them.

Figure 2-1 Unpack and Check

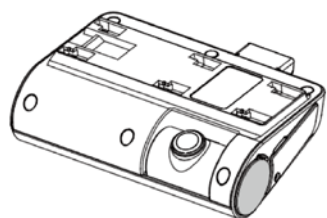

Dash Camera×1

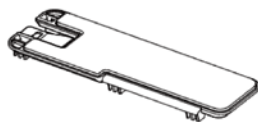

Bracket×1



L wrench×1



Manual×2

2.2 Device Structure

2.2.1 Top Cover

Describes the functions of the front indicator lights and ports.

Figure 2-2 Top Cover

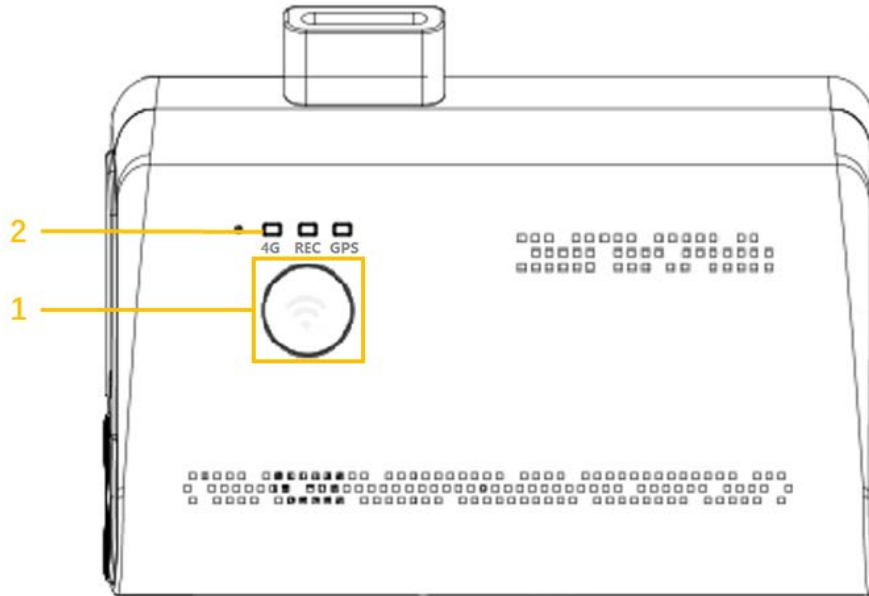

Table 2-1 Descriptions of ports and indicators

No.	Name	Descriptions
1	Hot Spot Button	Press the button to enable or disable the hot spot.
2	Indicator Light	<ul style="list-style-type: none"> ● 4G <ul style="list-style-type: none"> ◇ On: 4G is connected. ◇ Off: 4G is not connected. ● REC: <ul style="list-style-type: none"> ◇ On: The camera is recording. ◇ Off: The camera is not recording. ● GPS: <ul style="list-style-type: none"> ◇ On: GPS is normal. ◇ Off: GPS is abnormal.

2.2.2 Side Panel Ports

Describes the ports functions of the side panel.

For the ports of the side panel, see Figure 2-3, Table 2-2 for ports function description, and “2.2.3 Port Definition” for port definition.

Figure 2-3 Side Panel Ports

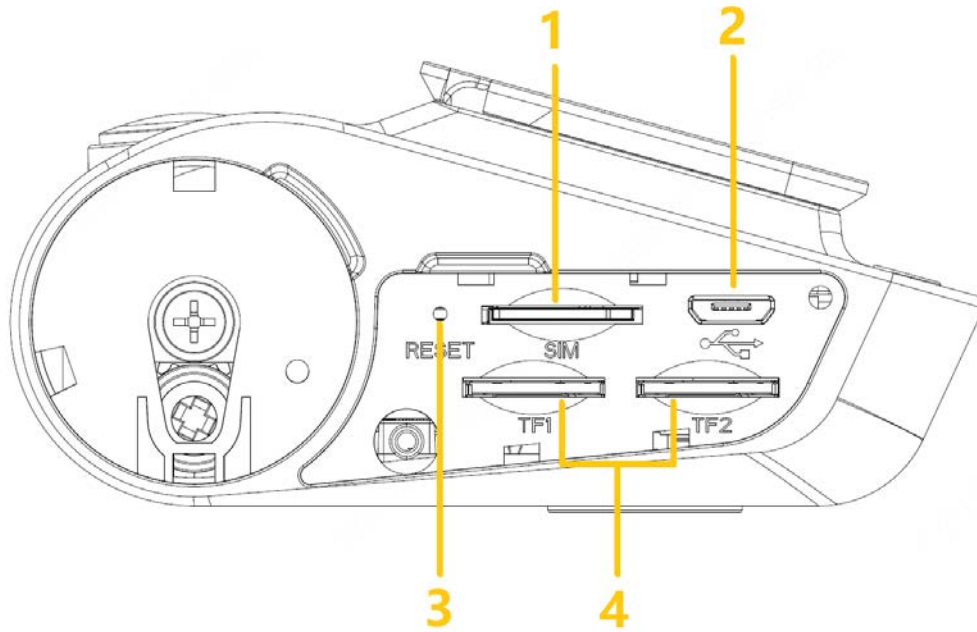

Table 2-2 Side panel port description

No.	Name	Function
1	SIM Card Port	Insert SIM card
2	USB Port	Connect the USB through an adapter cable.
3	RESET Button	Button for device reset
4	TF Card Port	Insert TF card

2.2.3 Port Definition



This manual only describes functions of each ports. You can follow these descriptions to prepare cables or contact our sales staff for purchasing cables.

2.2.3.1 Video Input Port

Figure 2-4 Video Input Port

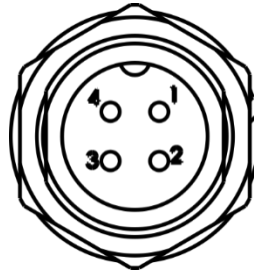

Table 2-3 Video input port description

Name	Description
1	VCC
2	Signal ground
3	Power ground
4	Signal

2.2.3.2 Network Port

The dash camera is not pre-installed with the RJ45 network interface and must use Micro-USB to convert to RJ45 transfer cable before it can be connected.

2.2.3.3 Power Input

Figure 2-5 Power Input Port

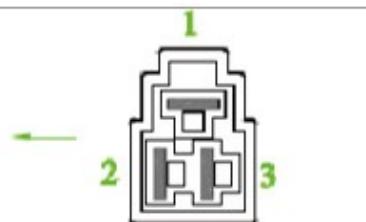

Table 2-4 Power input port description

Name	Pins	Cable Color
1	Ground	Black

Name	Pins	Cable Color
2	ACC Signal Input	Orange
3	Anode Input	Red

Table 2-5 Cable Description (1)

Color	Pins
Green	Alarm input _ 1
Blue	Alarm input _ 2
White	Alarm input _ 3
Yellow	RS232_TX
Orange	RS232_RX
Black	RS232_GND

2.2.4 Dimension

Figure 2-6 Dimension (Unit: mm [inch])

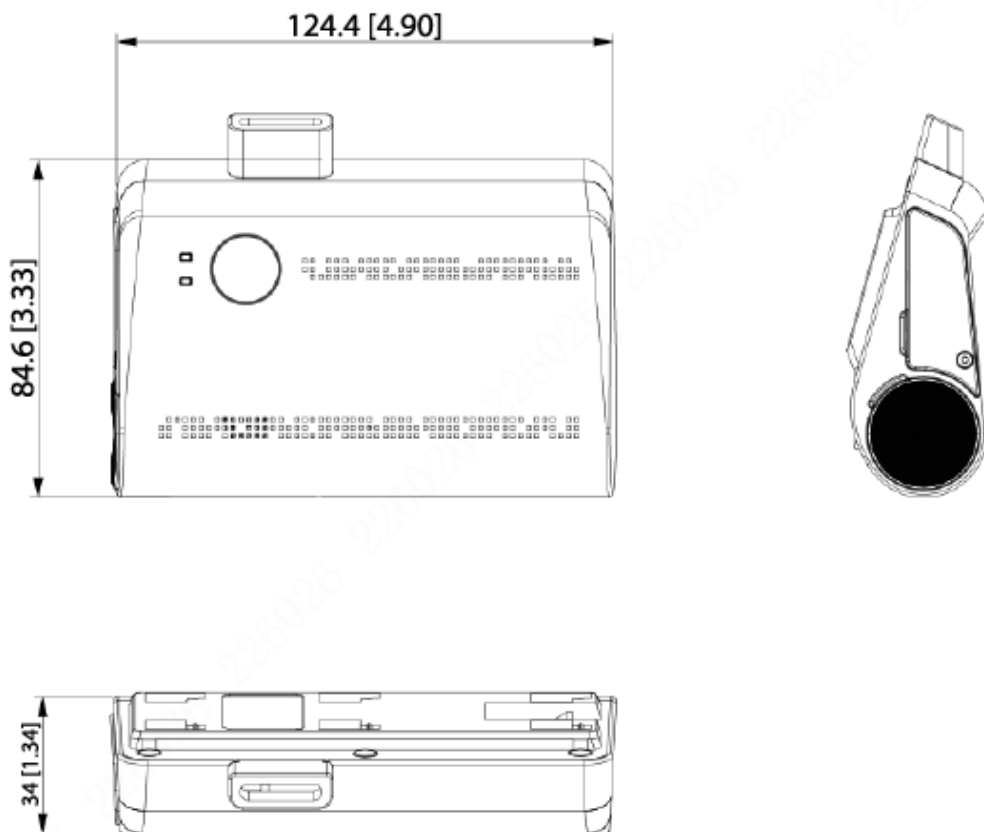

2.3 Device Installation

When you receive the device, unpack the box to check the device appearance and structures, and then install SIM card, and other items according to your network situation and storage requirement.



Before the installation is completed, make sure the device is disconnected from power, and do not plug or unplug components when the power is connected.

2.3.1 Installing SIM Card and TF card

The SIM card and TF card are not provided with the device by default. To connect the device to network through dial-up connection, you need to purchase and install a SIM card. To store recording data, you need to purchase and install the TF card.

Step 1 Use the standard T6 wrench to loosen the screws and disassemble the card cover.

Step 2 Insert the SIM card and TF card into the card slot with corresponding marks.

Figure 2-7 Installing SIM card and TF card

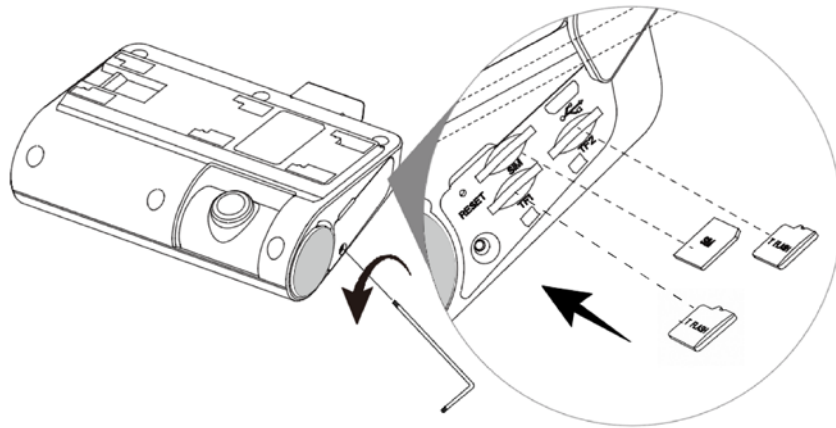

Step 3 Close the card cover and tighten the screws with a T6 wrench. SIM card and TF card are installed.

2.3.2 Installing Camera



- The best installation position of the dash camera is near the front windscreen and rear-view mirror, which is **horizontally centered** with the windshield.
- During installation, please adjust the position of the camera according to the actual situation to avoid blocking the driver's vision.

Step 1 Wipe the windshield clean, make sure there is no dust, and remove the backside glue on the bracket.

Figure 2-8 Remove the backside glue

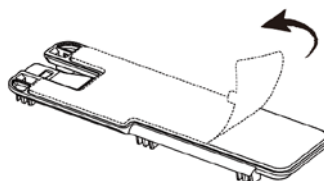

Step 2 Stick the bracket on the windshield and squeeze it with appropriate force to ensure that there are no bubbles.
After the bracket is stuck firmly, it is recommended to let it stand for 4 hours before installing the dash camera.



The bracket must be level with the windshield to avoid affecting the calibration.

Figure 2-9 Installing bracket

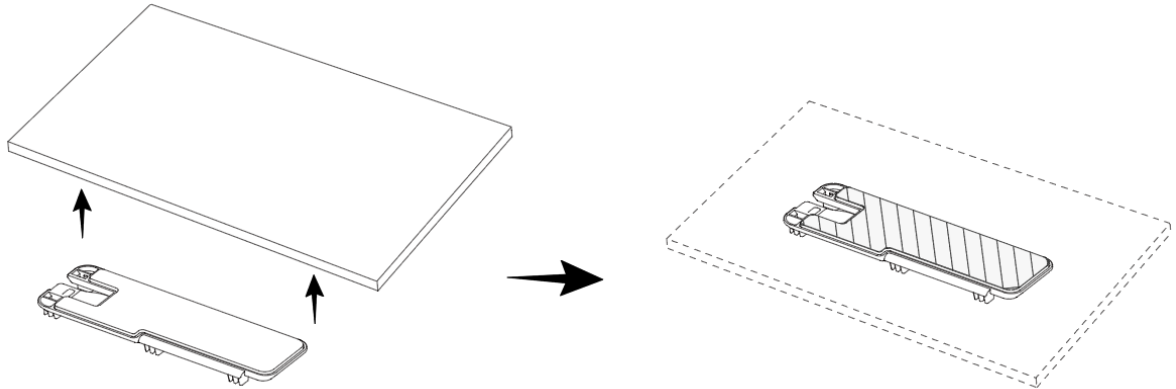

Step 3 Align the groove of the dash camera with the buckle on the bracket, slide the camera until you hear a "click" as shown in Fix bracket, and fix the body to the mounting bracket.

Figure 2-10 Fix bracket

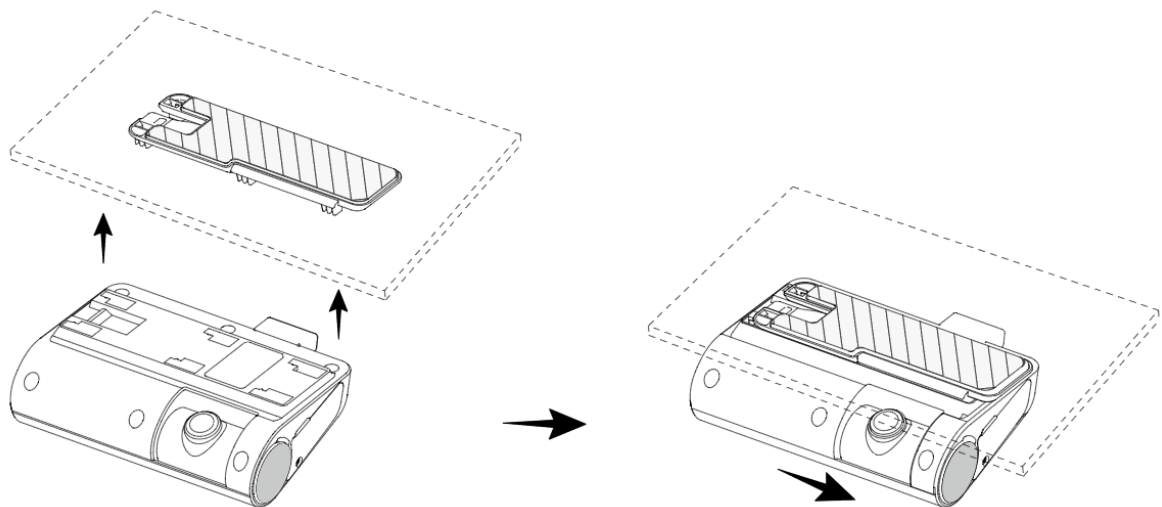

Step 4 Connect cables to the device. For details, see "2.4Cable Connection".

2.3.3 Adjusting Angle

After the camera is powered on, log in to the WEB interface to preview the video image in real time, and adjust the camera angle according to the image to align it with the required monitoring position. Please refer to "3.3Logging in to Device" for logging into the WEB interface.

Step 1 Open the cover on the side of the camera, and use a PH1 screwdriver to loosen the fixing screw.

Figure 2-11 Loosen the fixing screw

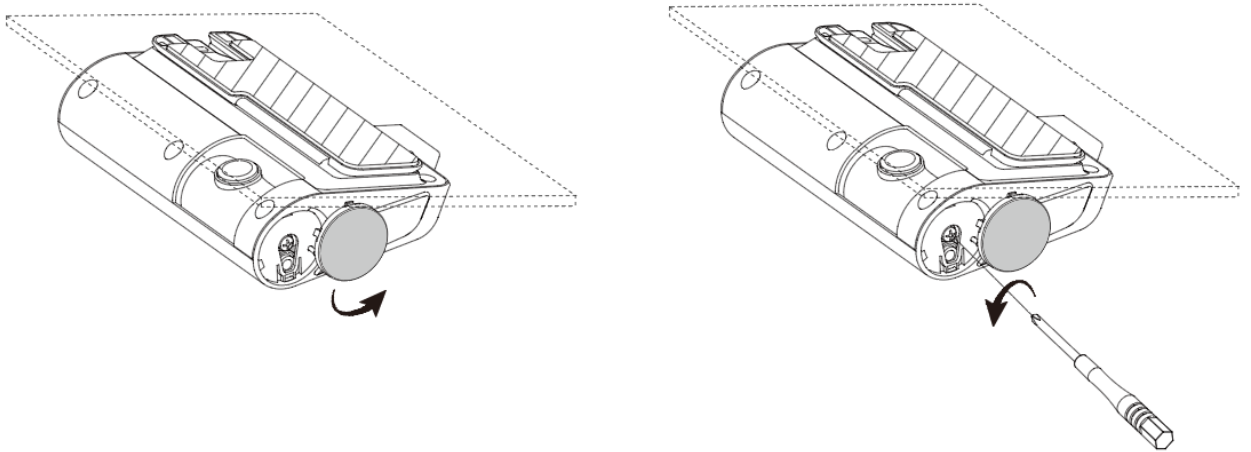

Step 2 According to the video image, use PH1 screwdriver to rotate the lens adjustment slot to adjust the lens angle.

Figure 2-12 Adjusting lens

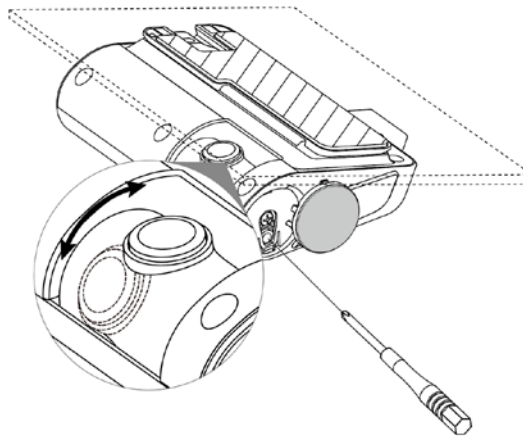

2.4 Cable Connection

2.4.1 Connecting Power Cable



- Before connecting the power cable, confirm whether the input voltage is between 9V DC and 16V DC. If it is out of the range, it will damage the device.
- Please make sure that the positive and negative poles of the power are connected correctly. If not, the device may be damaged.
- The diameter of power cable should be more than 1.0mm². Use power cables recommended by our company.
- When connecting the cables to the device, make sure that the main power switch of the vehicle is turned off and the key of the vehicle is placed in the off state.

2.4.1.1 Overview

For the power cable of the device, see Figure 2-13.

Connect one end of the power cable to the power port of the device (the left port in the figure), connect the other end to the vehicle battery (the right port in the figure).

- The black one is the grounding cable.
- The red one with fuse is positive pole of the power (always-live wire).
- The orange one is the ACC signal (key starting wire).

Figure 2-13 Power Cable

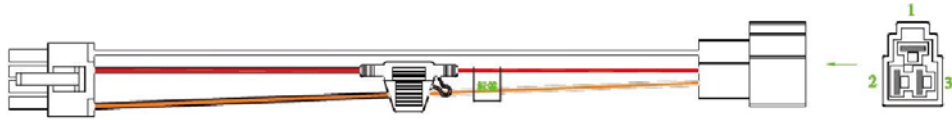

2.4.1.2 Obtain Connection Modes

In order to ensure correct cable connection, it is necessary to obtain the connection mode of the main power switch through three methods.

- Ask the vehicle manufacture the connection modes of the main power switch of the vehicle.
- Measure with a multimeter: disconnect the main switch, then measure the voltage between the vehicle body and the positive pole of the vehicle battery. If the voltage is 12V or 24V, it means that the main switch disconnects the positive pole. If the voltage is 0V, then the main switch disconnects the negative pole.
- Visual inspection: whether the switch cable near the vehicle battery is connected to the positive pole or the negative pole.

2.4.1.3 Connecting Operation

The dash camera must be connected to the ground wire, ACC signal, and constant electricity.

Step 1 Enable the main power switch on the vehicle, place the key in the OFF state, and then measure the normal live electricity of the vehicle.

Use a multimeter to measure the voltage on the fuse by switching to the DC voltage range. When the multimeter detects voltage, it measures the normal live electricity on the vehicle. Generally, the voltage is 24V DC for large vehicles and 12V DC for small vehicles. However, this is subject to actual data.

Step 2 When the vehicle key is placed at the ACC state or the ON state, the ACC signal of the vehicle is measured.

Use a multimeter to measure the voltage on the fuse by switching to the DC voltage range. When the multimeter detects voltage, remove the car key. If the voltage changes to 0V, it means that the measured signal is ACC on the car.

Step 3 Turn off the main power switch on the vehicle, and place key in the OFF state.

Step 4 Connect the power cable according to the main power switch installation mode. See Figure 2-14 and Figure 2-15.



- The positive and negative poles of the battery must be equipped with protective devices such as fuses.
- For vehicles where the master power switch is installed at the cathode of the accumulator, isolation installation is needed.

Figure 2-14 Vehicle main power switch installed on the positive pole of the vehicle battery

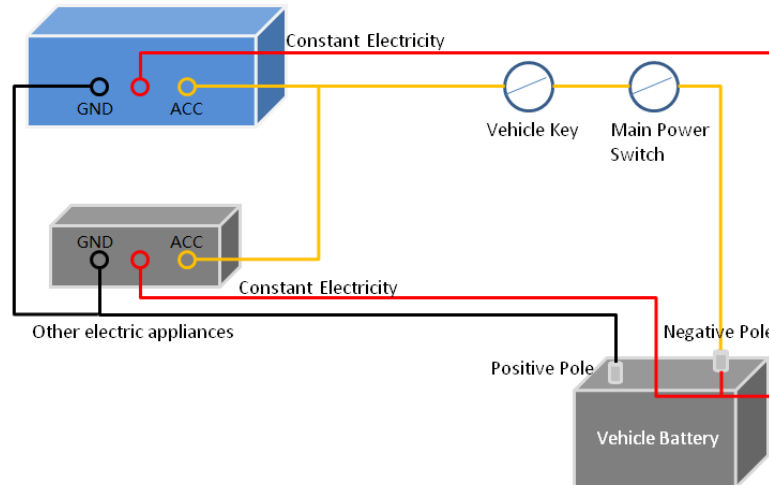
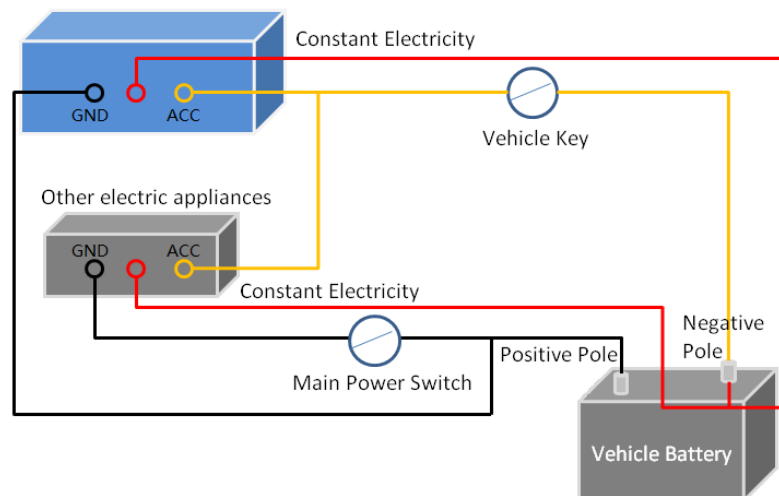

Figure 2-15 Vehicle main switch installed on the negative pole of the vehicle battery



2.4.2 Alarm Input Connection

Before using the alarm function, learn about the connections method of alarm input connection.

Alarm Input

- The alarm input port supports alarm signal from ground and device of 12V-24V voltage.
- If the alarm device is connected to the device and other devices, use relay for isolation.

No restriction for types of alarm input

The alarm input can be Normally Opened or Normally Closed.

2.4.2.1 Alarm Input Port Introduction

Describes the function of alarm input ports.

Figure 2-16 Alarm Input Ports

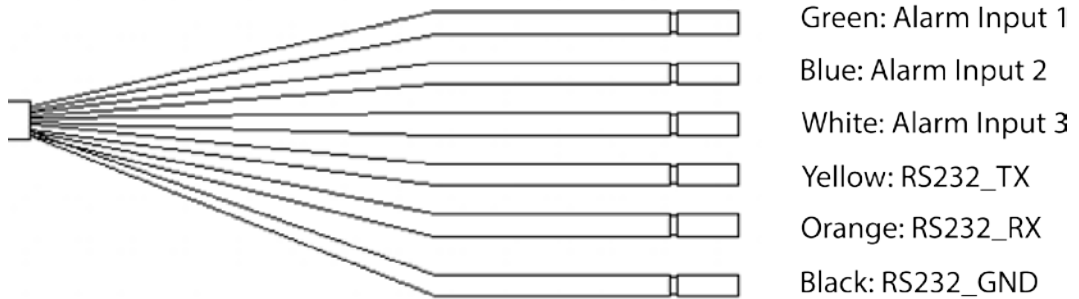

Table 2-6 Alarm input ports description

Name	Description
Alarm Input Port	Alarm Input Port 1-3, local alarm input port

2.4.2.2 Alarm Input Port Description

- Both NO and NC are supported.
- The GND of alarm detector is in parallel connection with COM (the power supply of alarm detector should be from external power source). See Figure 2-17.
- The GND of alarm detector is in parallel connection with GND of device.
- Connect the NC port of alarm detector to the alarm input port (ALARM).
- When supplying power from external power source to the alarm device, the alarm device should be common-grounded with the device.

Figure 2-17 NC alarm input

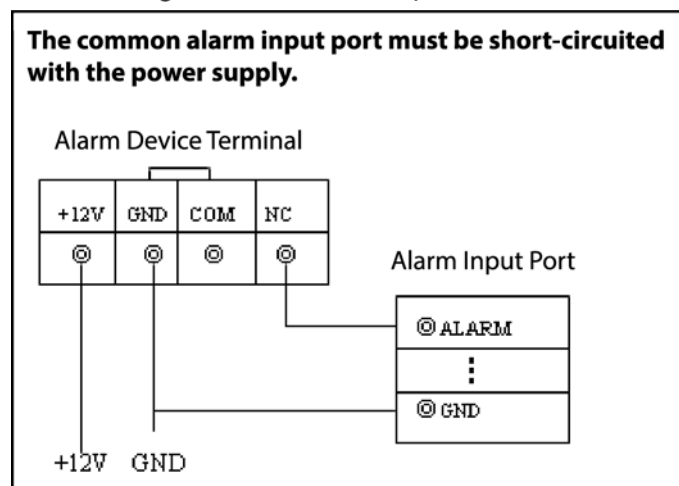

2.4.3 Cable Layout

Use the extension cable to connect the power supply and alarm input port, and lay cables as shown in the figure.



The camera is not equipped with extension cable by default, please purchase it as needed.

Figure 2-18 Cable layout

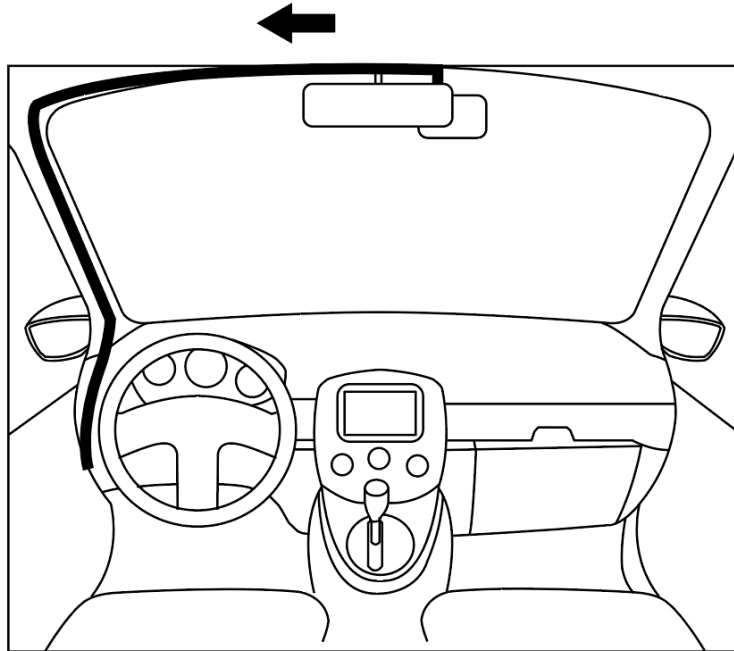

3 Basic Configuration

This device can be operated following instructions on the APP or WEB interface. This section introduces the WEB interface instructions. The local interface is similar and would not be elaborated here.



- There are several browsers supported, including Safari, Firefox, and IE.
- Click **Refresh**, the system displays the latest saved configuration.

3.1 Starting Device



- Before turning on the device, check whether the input voltage is correct against the device power requirement.
- To ensure the stable work of the device and the external devices connected to the device and to prolong the service life, we recommend that you should refer to the national related standard to use the power source that provides stable voltage with less interference from ripples.
- In the first power-on, the device needs connection to the ACC to work as intended.



For the first boot up or after restoring to the default factory settings, the initialization interface is displayed on the screen. Follow on-screen instructions to initialize your device prior to use.

3.2 Initializing Device

When you are opening the device for the first time or you have allowed your system to be restored the factory settings, you need to initialize the device. Only after that can you operate and configure your device.

Prerequisites

Please make sure the correct network connection between PC and the device.

Procedure

- Step 1 Open the browser, enter the device IP address (the default IP address is 192.168.1.108), and then press **Enter**.
The **Device Initialization** interface is displayed. See Figure 3-1.

Figure 3-1 Device Initialization

The screenshot shows a dark-themed interface titled "Device Initialization". It features three dropdown menus for configuration: "Region" with the text "Please select an item.", "Language" with "English" selected, and "Video Standard" with "PAL" selected. A "Next" button is located in the bottom right corner.

Step 2 Set the **Region**, and click **Next**.

The **Password Setting** interface is displayed. See Figure 3-2.

Figure 3-2 Password Setting

The screenshot shows a dark-themed interface titled "Device Initialization". At the top, it displays a progress indicator with "1.Password Setting" in blue and "2.Password Protection" in white, separated by a right-pointing arrow. Below this, the "Username" field is pre-filled with "admin". The "Password" and "Confirm Password" fields are empty text boxes. To the right of these fields, a password requirement note states: "Password must be 8 to 32 characters, including at least two of the following categories: numbers, uppercase letters, lowercase letters and special characters (Characters like ' ' ; : & cannot be included in).". A blue "Next" button is located in the bottom right corner.

Step 3 Enter the **Password** and enter it again in the **Confirm Password** box. Click **Next**.

The **Password Protection** interface is displayed. See Figure 3-3.

Figure 3-3 Password Protection

Device Initialization

1.Password Setting → 2.Password Protection

Reserved Email

For password reset. Recommended or improved in time.

Security Question

Question 1

Answer

Question 2

Answer

Question 3

Answer

OK

Step 4 Select the reset type based on your needs. It is recommended to enable the two types as follows.

- Select **Reserved Email** and then enter email address.
- Check the **Security Question** box, select the question and enter the corresponding answer.

Step 5 Click **OK**.

Device initialization completed.

3.3 Logging in to Device

You can log in to and then configure the device.

Step 1 Open the browser, enter the device IP address, and then press **Enter**.

The **WEB Login** interface is displayed. See Figure 3-4.

Figure 3-4 WEB login



Step 2 Enter user name and password, and then click **Login**.



For admin account, if you forget password, click **Forgot password?** to find back the password.

For details, see "5.8.3 Resetting Password".

Figure 3-5 WEB interface

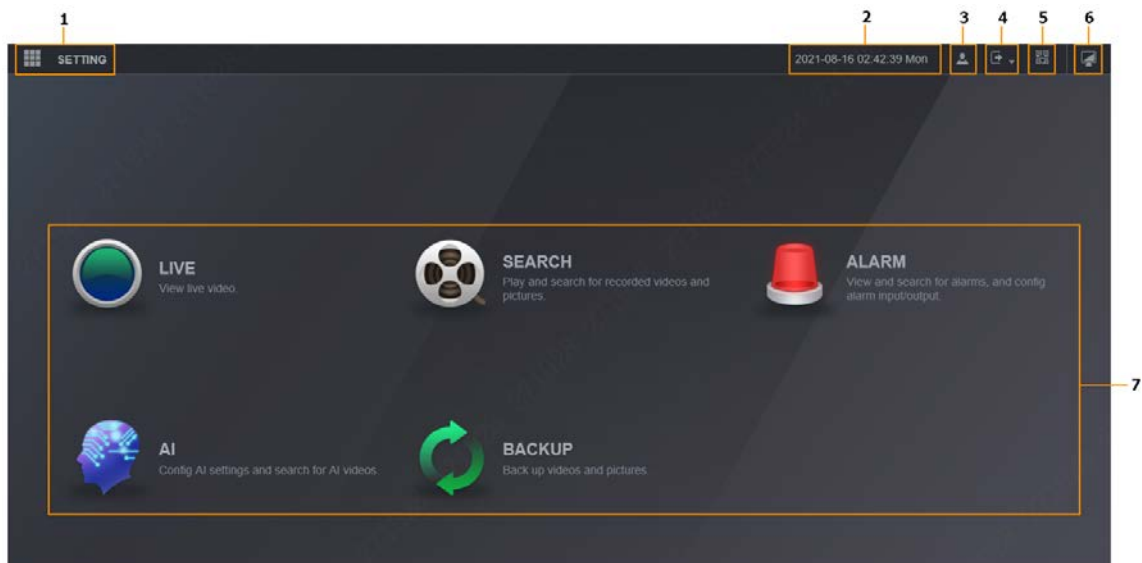

Table 3-1 WEB interface description





No.	Name	Description
1	Setting	Click  or Setting , the system displays as Figure 3-6. Click the icon to go to the configuration interface.
2	Time	Display the current time.
3	User	Display the user that currently logs in.
4	Logout	Click  , the system displays as Figure 3-7. Select Log Out or restart the device as needed.
5	QR Code	Click  , the system displays as Figure 3-8. Scan device serial number to add the device to APP.
6	Desktop	Click  to return to WEB main interface.
7	Operation	System operation

Figure 3-6 Setting

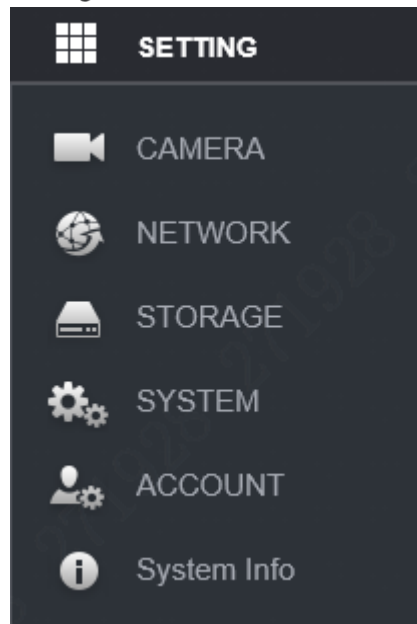

Figure 3-7 Logout

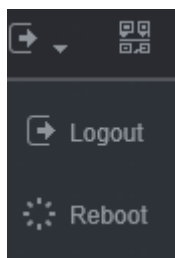
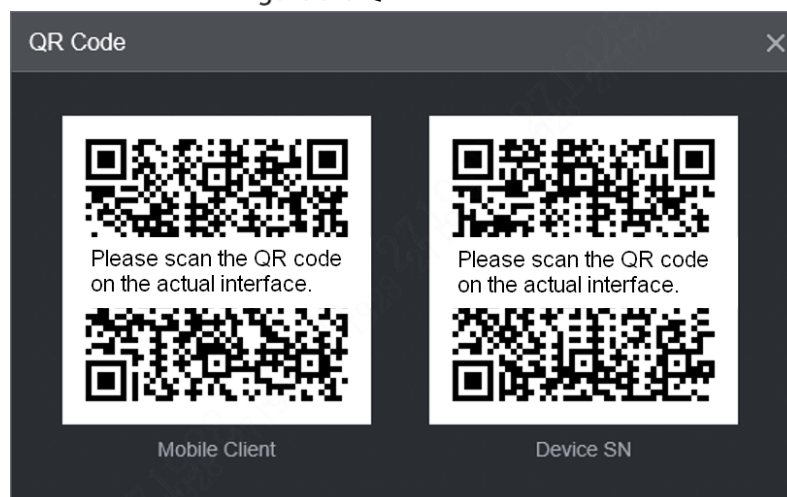

Figure 3-8 QR Code



3.4 Configuring IP Address

Connect the device to the network and make sure the device can communicate with other devices in the network diagram.

Prerequisites

Make sure the device is connected to the network properly.

Procedure

- Step 1** Select Setting > Network > TCP/IP.
The **TCP/IP** interface is displayed. See Figure 3-9.

Figure 3-9 TCP/IP

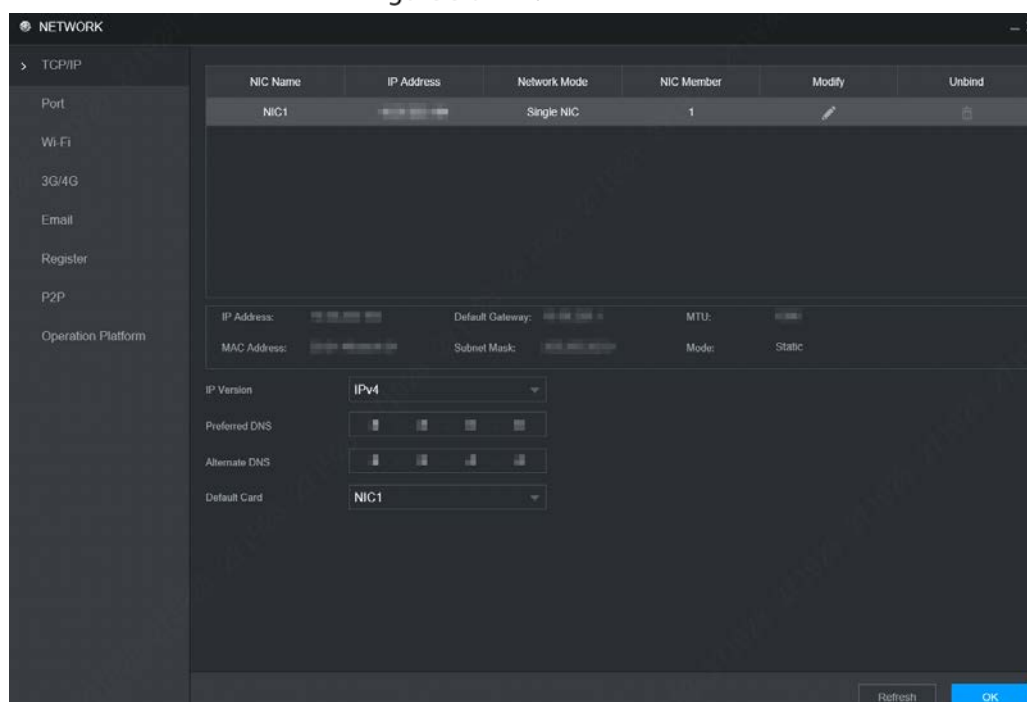

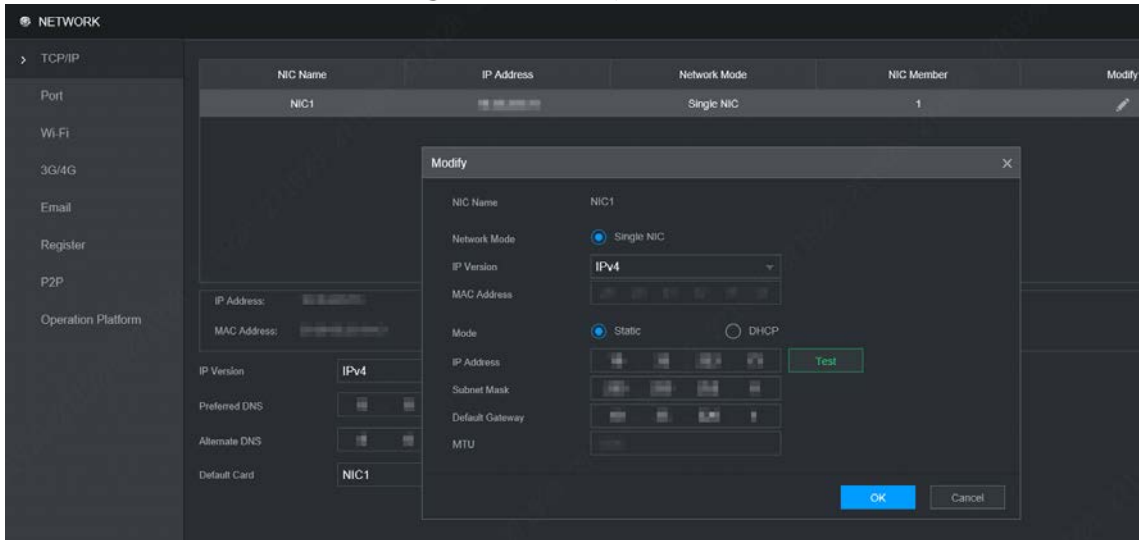

Step 2 Click **Modify**. The **Modify** interface is displayed. See Figure 3-10.

Figure 3-10 Modify



Step 3 Configure parameters. For details, see Table 3-2.

Table 3-2 TCP/IP parameters

Parameter	Description
IP Version	Select IPv4 or IPv6 . Both versions are supported.  For IPv6 version, in the IP address box, the Gateway box, the Preferred DNS box, and the Alternate DNS box. Please enter 128 bits and it cannot be blank.
MAC Address	Indicates the device MAC address which cannot be modified.
DHCP	Select the DHCP box, the system automatically obtains an IP address. When the DHCP function is enabled, the IP address , Subnet mask and Default gateway cannot be set manually.  No matter the DHCP function is enabled or not, you can view the current IP address.
IP Address	According to your network plan, enter the modified IP address, gateway and subnet mask.  Please ensure IP address and subnet mask are in the same network segment, which means the front parts of the IP address and of the default gateway are the same one.
Subnet Mask:	
Default Gateway:	
Preferred DNS	IP address of DNS server.
Alternate DNS	IP address of Alternate DNS.

Step 4 Click **OK**.

3.5 Configuring General Settings

You can configure the basic settings, including time and date settings.

3.5.1 General Settings

Set up the general information of the device, including language, video standard duration, license plate, and more.

Step 1 Select Setting > System> General > Basic.

The **Basic** interface is displayed, see Figure 3-11.

Figure 3-11 Basic

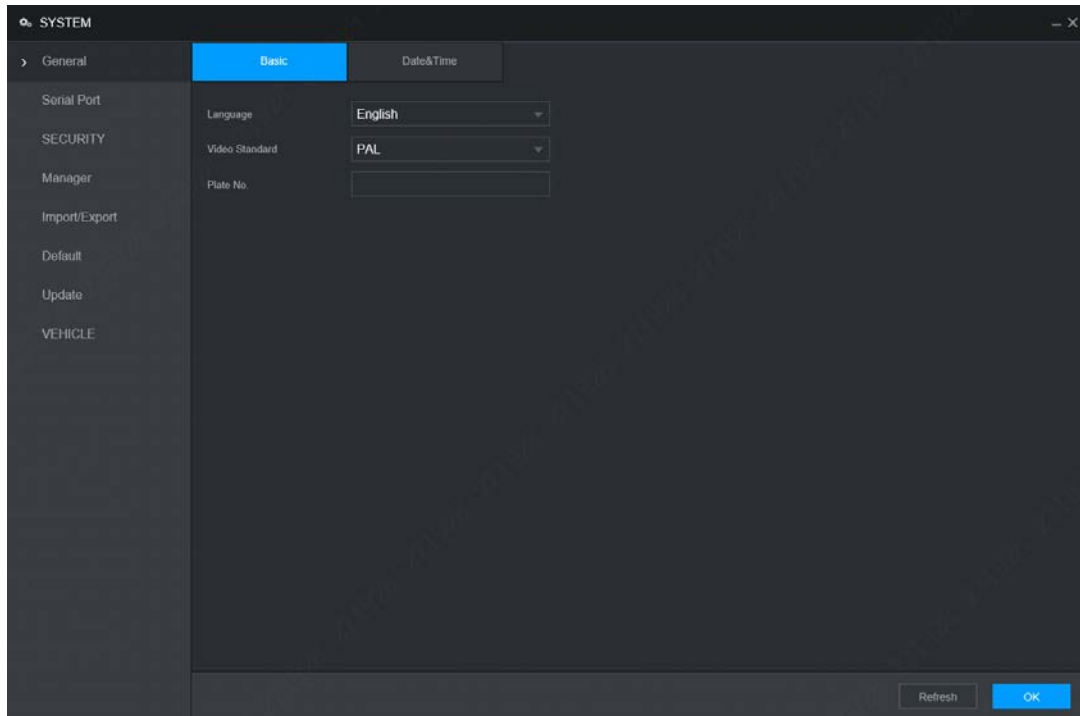

Step 2 Configure parameters. For details, see Table 3-3.

Table 3-3 General settings parameter description

Parameter	Description
Language	Select a language for the device system.
Video Standard	Displays the video encode standard.
Plate No.	Enter the license plate number of vehicle where the device is located.

Step 3 Click **OK**.

3.5.2 Date&Time

You can configure settings such as date format, time format, and timing mode.

Step 1 Select Setting > System > General > Date&Time.

The **Date&Time** interface is displayed. See Figure 3-12.

Figure 3-12 Date&Time

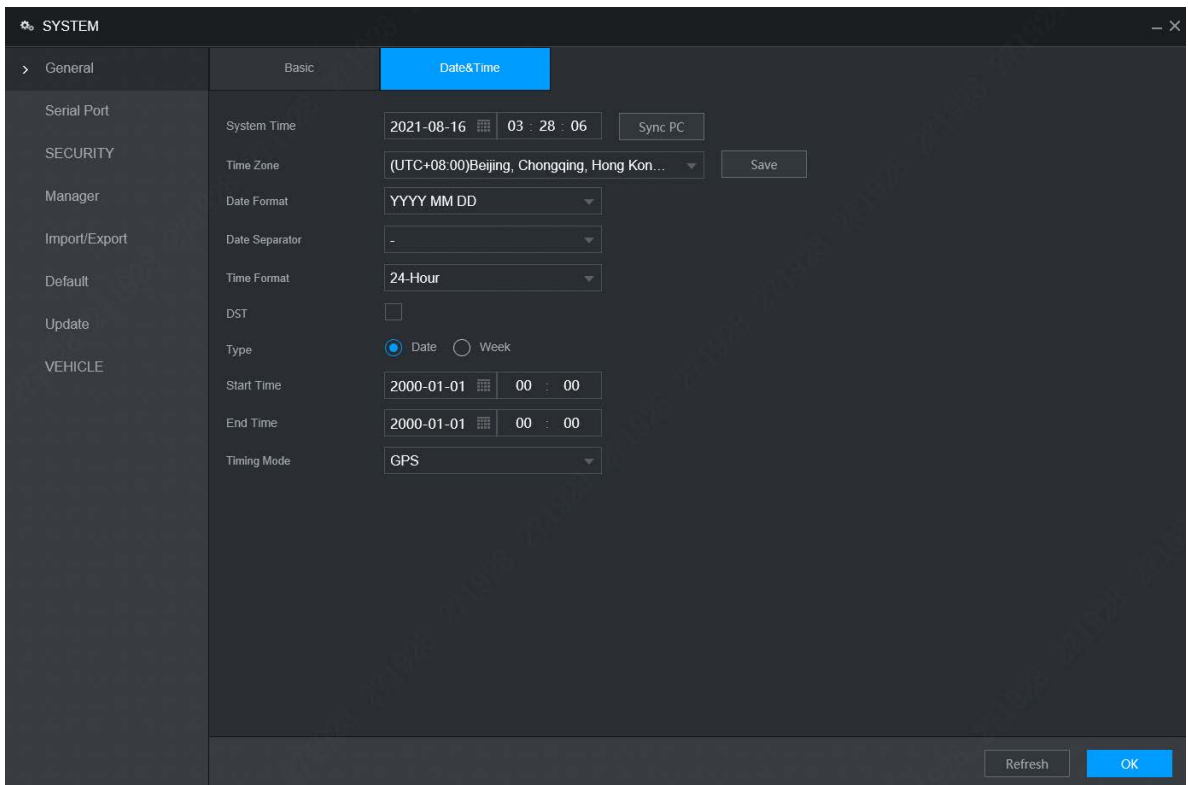

Step 2 Configure parameters. For details, see Table 3-4.

Table 3-4 Date&Time parameters description

Parameter	Description
System Time	Displays the current system date and time.
Time Zone	The time zone where the device locates. In the Timing Mode list, if GPS or NTP is selected, configure this parameter.
Date Format	Set the date display format of the device, including YYYY-MM-DD, MM-DD-YYYY and DD-MM-YYYY.
Date Separator	Separator style of date.
Time Format	Select a time format, including 24-hour and 12-hour.
DST	The DST is applied in some countries or regions. Select the DST check box if it is applied where the device is located
DST Type	
Start Time	
End Time	1. Select the DST check box. 2. According to the local regulations, configure the type, start time and end time for the DST.
Timing Mode	Select a timing mode, including DSS, GPS, and NTP. The default selection is NTP. <ul style="list-style-type: none"> ● DSS: The system time syncs with DSS platform. ● GPS: The system time syncs with satellite. ● NTP: The system time syncs with NTP server that you configured.
Server Address	In the Timing Mode list, if NTP is selected, configure this parameter. After configuring NTP server, the device syncs time with NTP server.
Port	

Parameter	Description
Interval	<ol style="list-style-type: none"> In the Timing Mode list, select NTP to enable the NTP timing function. Configure parameters. <ul style="list-style-type: none"> ◇ Server: Enter IP address of NTP server. ◇ Synchronize: Click Manual Update to sync the device time with NTP server. ◇ Port: The system supports TCP protocol only and the default setting is 123. ◇ Interval: Enter the interval that you want the device to sync time with the NTP server. The maximum value is 65535 minutes.

Step 3 Click **OK**.

3.6 Configuring Record Mode

The record mode is consisted of manual mode and auto mode. You can also enable or disable the snapshot function.

- Auto: The recording starts automatically according to the record type and recording time as configured in the recording schedule.
- Manual: Keep general recording for 24 hours for the selected channel.



Manual recording operation requires the user have the permission to access **Storage Settings**.
Check to ensure the HDD installed in the device has been formatted properly.

Step 1 Select Setting > Storage > Record Mode.

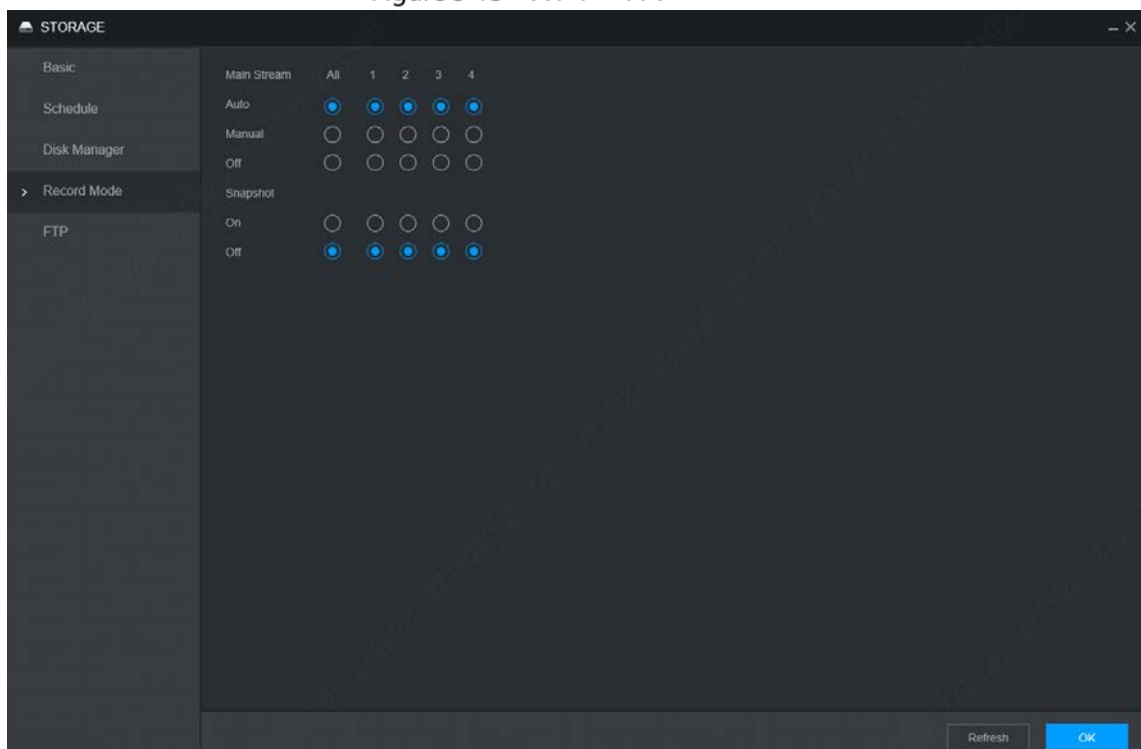

The **Record Mode** interface is displayed. See Figure 3-13.

Figure 3-13 Record Mode



Step 2 Configure parameters. For details, see Table 3-5.

Table 3-5 Recording control parameters description

Parameter	Description
Channel	Displays the channel number. You can select one or several channels or select All .
Status	Indicates the recording status of corresponding channels. The choices include Auto, Manual, Enable, and Close. <ul style="list-style-type: none"> ● : Selected. ● : Not selected.
Auto/Manual/Off	Select the recording mode, including Manual, Auto, and Off <ul style="list-style-type: none"> ● Manual: Top priority. When the Manual check box is selected, the system keeps general recording for 24 hours for the corresponding channel. ● Auto: The system starts recording according to the record type (such as general alarm, motion detect, and system alarm) and recording time. ● Off: Do not record.
On/Off	Enable or disable the scheduled snapshot for the corresponding channels.

Step 3 Click **OK**.

3.7 Configuring Storage Plan

3.7.1 Record Schedule

The default recording setting is 24 hours recording for all channels. You can configure the record type and recording time according to your actual situation.

Prerequisites

The auto record is enabled for the corresponding channel. For details, see “3.6 Configuring Record Mode”.

Procedure

Step 1 Select Setting > Storage > Schedule > Record.
The **Record** interface is displayed. See Figure 3-14.

Figure 3-14 Record

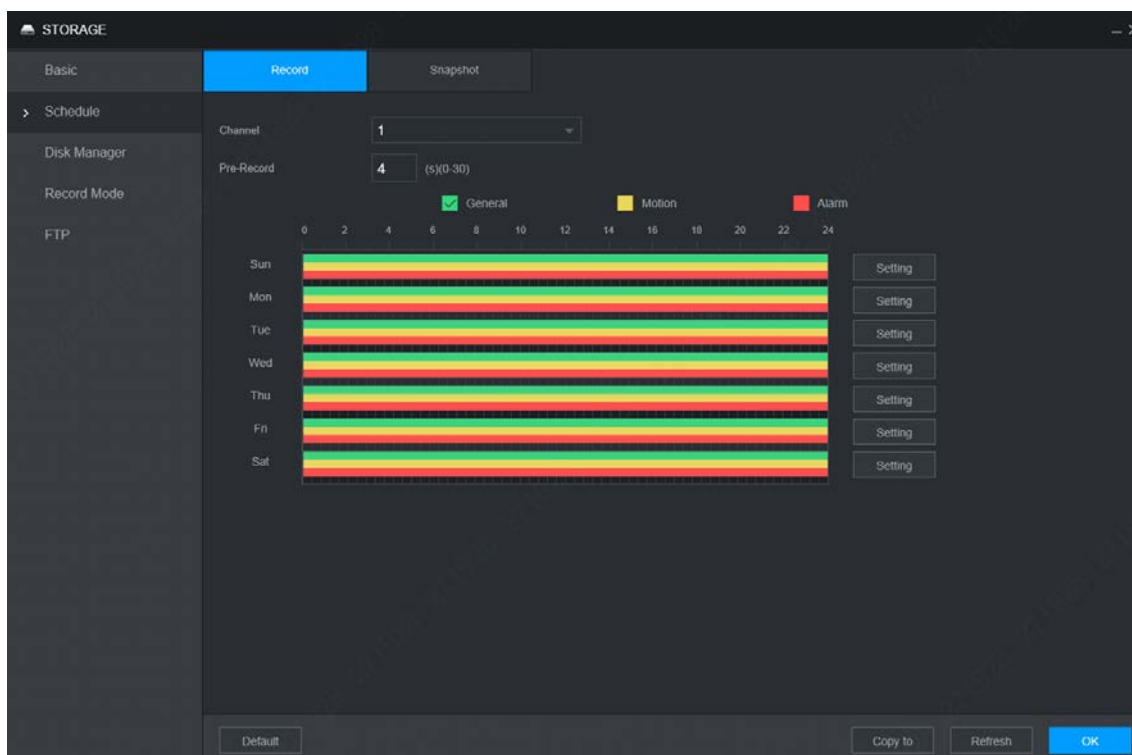

Step 2 Configure parameters. For details, see Table 3-6.

Table 3-6 Recording parameters description

Parameter	Description
Channel	Select a channel to configure the corresponding recording schedule. If you configure the same setting for all channels, select All .
Pre-record	Start recording for 0 seconds to 30 seconds before the alarm event occurs. If you enter 0 seconds, there will be no pre-recording.

Step 3 Set periods of the record by drawing or editing.

- Drafting method
 1. Select the type of recordings by selecting the check box in front of the type. See Figure 3-15.

Figure 3-15 Record type

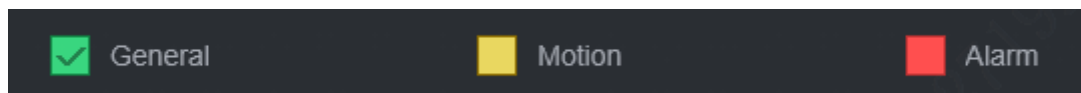

2. Press and hold the left button and drag the mouse in the period illustration to draft the period.
 There are six periods in one day. The device activates recordings of the preset type in each preset period. In the period illustration displayed in the figure, the color bar shows the **Recording Type** corresponding to the period.
 - ◇ Green means general recordings are effective.
 - ◇ Yellow means motion recordings are effective.
 - ◇ Red means alarm recordings are effective.

Figure 3-16 Draw

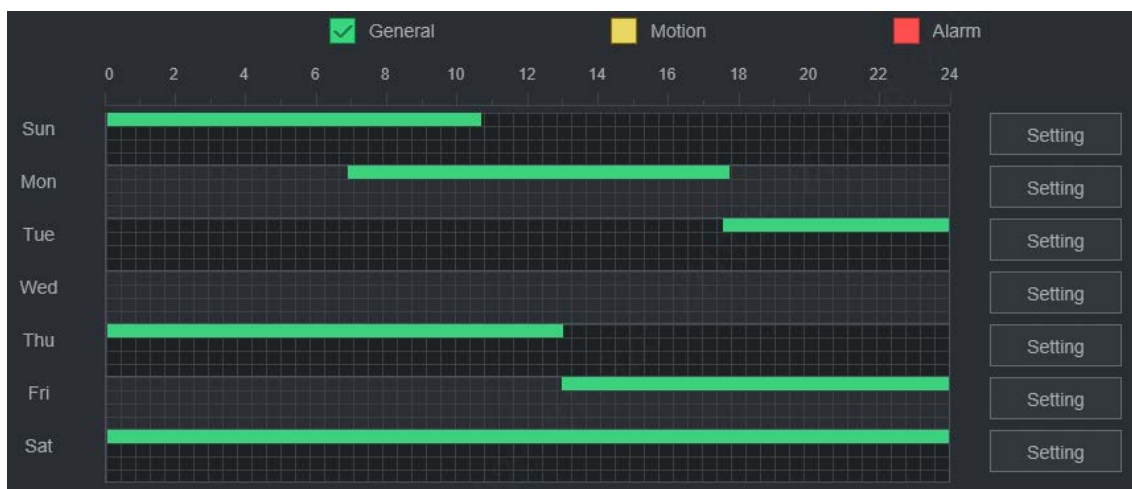

- Editing Method
 1. Click **Setting** corresponding to the week.
The **Setting** interface is displayed. See Figure 3-17.

Figure 3-17 Setting

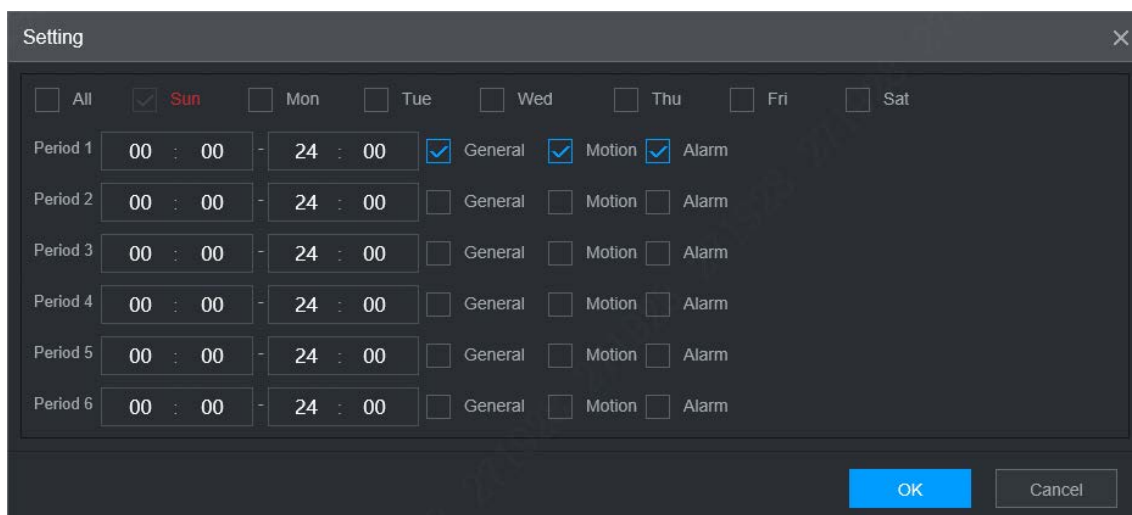

2. Select the record type and weekday, and enter the recording period.
3. Click **OK**.
The recording schedule appears on the **Recording Plan** interface to view the configured recording schedule directly.

Step 4 Click **OK**.



- Click **Copy to** and you can copy the settings to other channels.
- Click **Default**, and the device is restored to default configuration.

3.7.2 Snapshot Schedule

You can configure the storage schedule for taking the snapshot.

Prerequisites

The snapshot is enabled for the corresponding channel. For details, see “3.6 Configuring Record Mode.”

Procedure

Step 1 Select Setting > Storage > Schedule > Snapshot.

The **Snapshot** interface is displayed. See Figure 3-18.

Figure 3-18 Snapshot

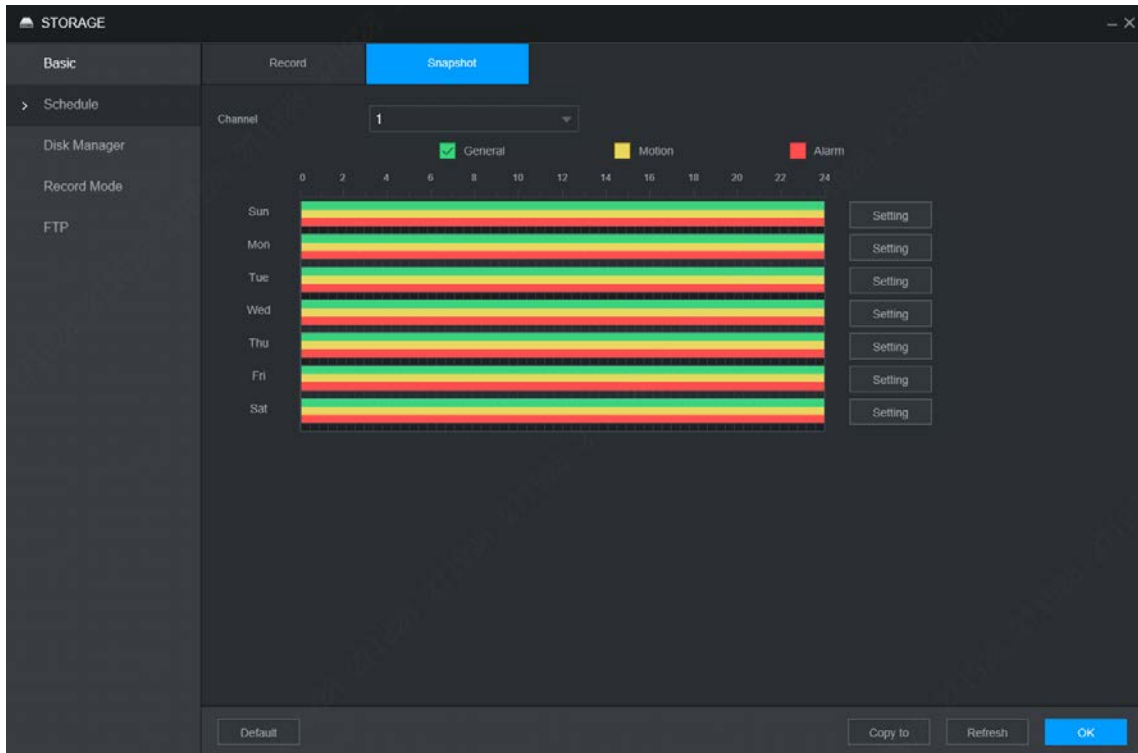

Step 2 Set snapshot period by drafting and editing.

- Drafting method
 1. Select the type of snapshot by selecting the check box in front of the type. See Figure 3-19.

Figure 3-19 Snapshot Type

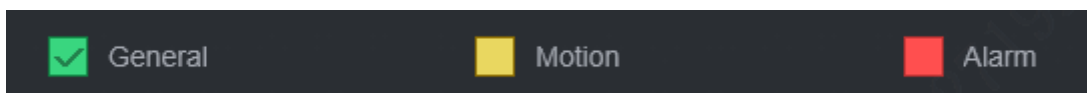

2. Press and hold the left button and drag the mouse in the period illustration to draft the period.

You can set six periods in one day. The device activates the snapshot method of the preset type in each preset period. In the period illustration displayed in the figure, the color bar shows the **Snapshot Type** corresponding to the period.

 - ◇ Green means general snapshots are effective.
 - ◇ Yellow means motion detection snapshots are effective.
 - ◇ Red means alarm snapshots are effective.

Figure 3-20 Draw

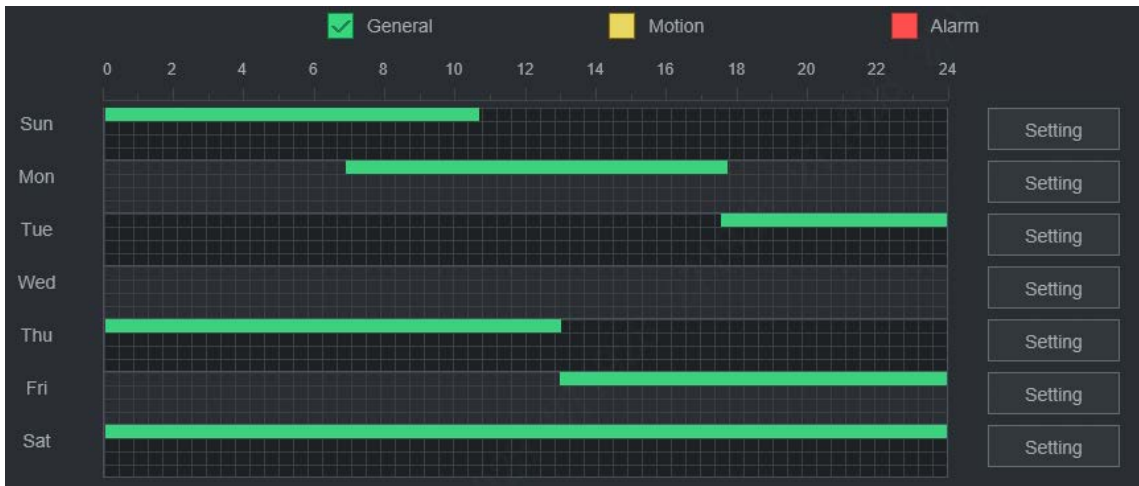

- Editing Method
 1. Click **Setting**.
The **Setting** interface is displayed. See Figure 3-21.

Figure 3-21 Setting

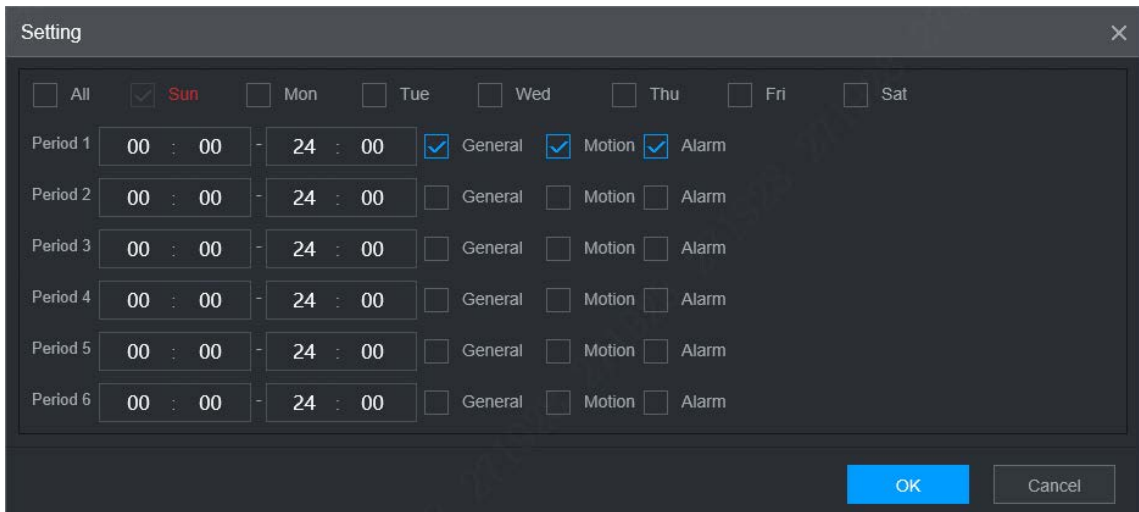

2. Select the snapshot type and weekday, and enter the period for taking snapshot.
3. Click **OK**.
Snapshot schedule appears on the **Snapshot** interface to view the configured snapshot schedule directly.

Step 3 Click **OK**.



- Click **Copy to** and you can copy the settings to other channels.
- Click **Default**, and the device is restored to default configuration.

4 Function Operations

4.1 Live

Log interface in and click **Live** tab, the **Live** interface is displayed, see Figure 4-1.

Figure 4-1 Live

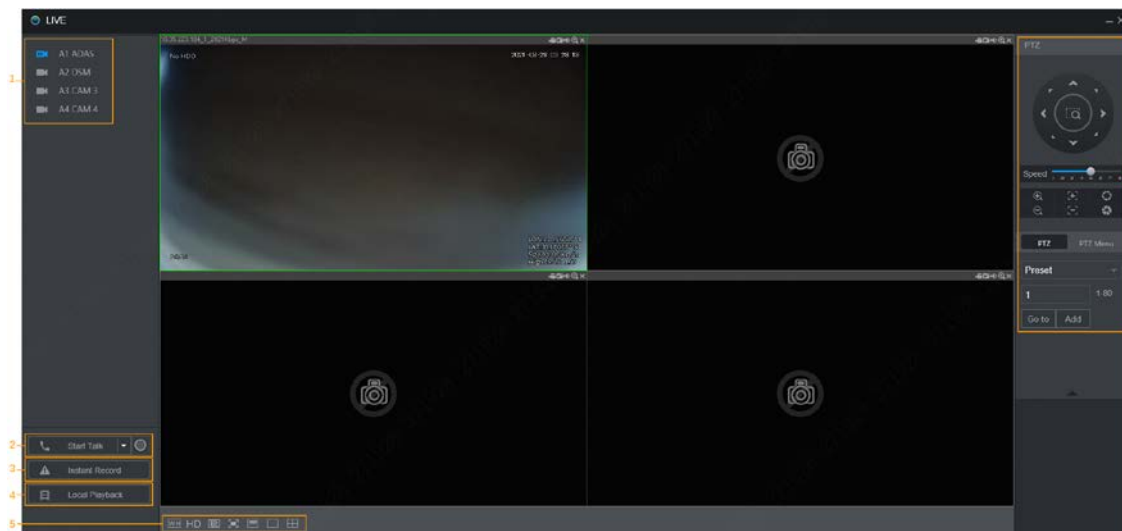
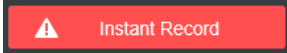



Table 4-1 Live interface parameters description

No.	Name	Description
1	Real-time monitoring channels	See "4.1.1 Real-time Monitoring Channels".
2	Start talk	Click Start Talk to communicate with the device. But you should plug in a microphone before .
3	Instant Record	Click Instant Record and the recording type switches to Manual, when the icon turns to  ; click Instant Record again to switch the record type back to Auto.  This function is only supported by main stream.
4	Local playback	Plays back the video file (dav) stored on the PC. Click Local Playback , select the video file in the pop-up dialog box, and then click Open to start playing back the video file
5	Window function operations	Configure the scale, image quality, playback fluency, full screen, and window split mode. For real-time monitoring, you can select the fluency or real-time to be the priority according to your actual requirement. Select  to split the preview window as necessary.

4.1.1 Real-time Monitoring Channels

Displays the list of monitoring channels.

Figure 4-2 Monitoring channels

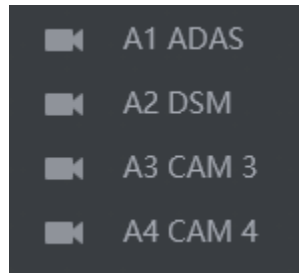

Operations in monitoring channels

Click any monitoring channel to display its live video on the screen. See Figure 4-3.

Figure 4-3 Video monitoring screen

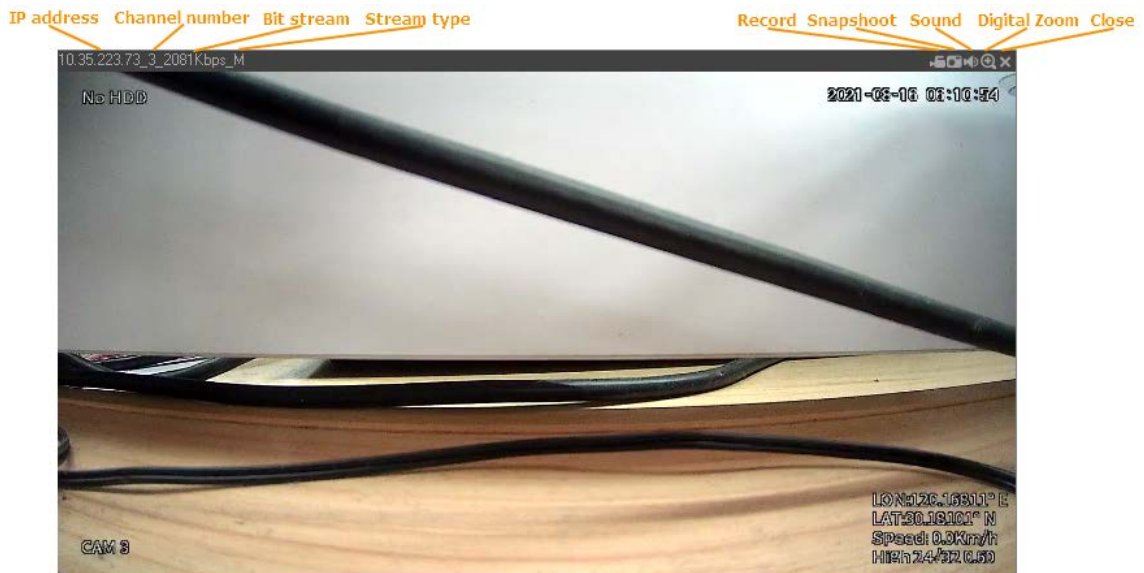



Table 4-2 Video monitoring window parameters description

Parameter	Description
Device Information	Displays the IP address, channel number, bit stream, and stream type (M represents main stream, S represents sub stream)
Record	Click this icon to start recording; click it again to stop recording.  The recorded files default storage path is C:\RecordDownload. You can modify this path if needed. For details, see "5.4.2.4Storage Path."
Snapshot	Click this icon to start taking snapshot.  The snapshots default storage path is C:\PictureDownload. You can modify this path if needed. For details, see "5.4.2.4Storage Path."

Parameter	Description
Sound	Turns on/off audio. If audio function is not enabled in the encode settings, the monitoring does not give sound
Digital Zoom	Click this icon and then hold down the left mouse button to select the area you want to enlarge. The area is enlarged. Click this icon again or right-click on the window to exit.
Close	Close the live view in the window.

Stream Type

The system supports switching between main stream and sub stream in real-time monitoring window. See Figure 4-4. For details about stream settings, see “5.4.2 Encode Parameters”.

Figure 4-4 Stream type

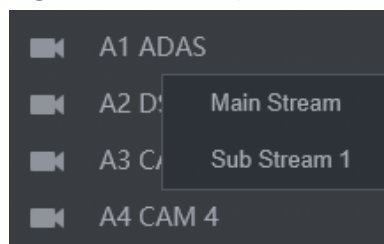

4.2 Video Playback

On the **Video Playback** interface, you can play back or download video recording files.

4.2.1 Playback operations

On the main WEB interface, click **Search**, and the **Search** interface is displayed. See Figure 4-5.

Figure 4-5 Video Playback

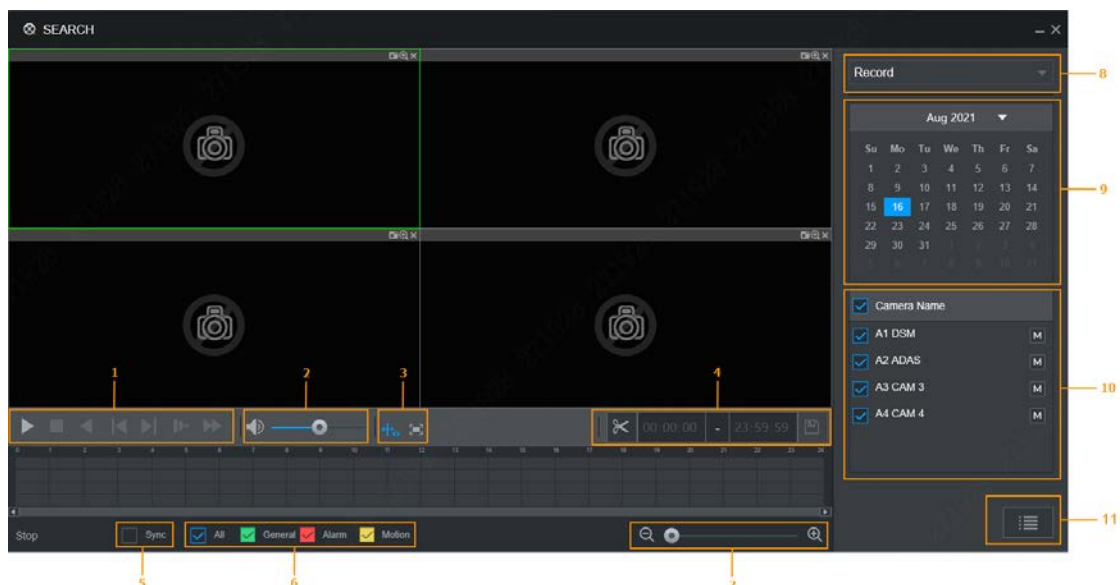

















Table 4-3 Function bar description

No.	Function	Description
1	Control bar	For detailed information about control buttons, see "4.2.4 Clipping Recording File".
2	Volume adjustment	Controls playback volume, including: <ul style="list-style-type: none">  means mute mode.  means normal playing and the volume can be adjusted.
3	Full screen button	To play the video recording in full screen.
4	Video clip	Clip a section of recorded video and save it. See "4.2.4 Clipping Recording File".
5	Sync	With Sync selected, when you click in the progress bar to play back the recordings, the playback time of other channels will sync with the selected channel in the following ways: <ul style="list-style-type: none"> If the playback time of other channels is before the time of the selected channel, other channels will speed up the playback till synced with the selected channel. If the playback time of other channels is after the time of the selected channel, other channels will pause to wait till synced with the selected channel.
6	Record Type	The record types include Regular, MD, and Alarm. You can select the type as needed.
7	Time bar	Move the slider or click  /  to adjust the time bar.
8	Playback Type	To select the playback type. Only record playback is supported at present.
9	Calendar	Click the date on which you want to play back the recorded video.
10	Channel List	You can set the cameras to focus on.  You can select up to 4 cameras.
11	File List	You can download recorded video by file type or time, and verify the completeness.

4.2.2 Control bar



Playback control buttons. For details, see Table 4-4.

Table 4-4 Playback controls bar introduction

Icon	Function	Description
	Broadcast	When this icon displays, it means the video is paused or not being played. You can click this icon to play the video.
	Stop	During playing back, click this icon to stop playback.
	Reverse Play	Click this icon to play the video recording backward.
	Previous Frame	Click this icon to jump to the previous frame.  You need to pause the playback before playing the next frame.
	Next frame	Click this icon to jump to the next frame.  You need to click the Stop icon before playing the next frame.
	Slow	Click this icon to adjust the slow playback speed. Click  to start slow playback.
	Fast	Click this icon to adjust the fast playback speed. Click  to start fast playback.

4.2.3 Playing Back Record Video Files

You can play back video recordings by time or file name. During playback, you can conduct the following operations.

- In the channel window, click  at the upper right corner and select the area you want to enlarge. The area is enlarged. Click this icon again or right-click in the window to exit.
- Click  at the upper right corner to take a snapshot.
- Click  at the upper right corner to close playback.

4.2.3.1 Playing Back Video Recordings by Date

Step 1 Select the date for searching for the video recordings, and set the corresponding channel as needed.

Step 2 Select a date with recorded video files, click on the window channel to select a playback channel, and then select the record type. See Figure 4-6.

Figure 4-6 Record Type

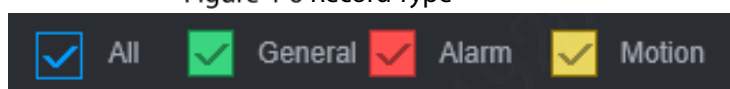

Step 3 Click  to start playing back recorded video.

4.2.3.2 Playing Back Video Recordings by File Name

Step 1 Select the date for searching for the video recordings, and set the corresponding channel as needed.

Step 2 Select a date with recorded video files, click on the window channel to select a playback channel.

Step 3 Click File List.

The video recordings are displayed in the list. See Figure 4-7.

Figure 4-7 File List

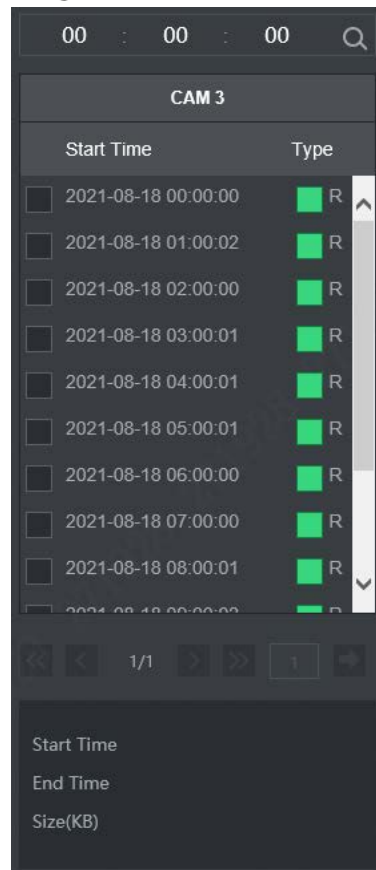

Step 4 Set the start time of the file to be searched for, and then click . The recording files are displayed.

Step 5 Double-click the video recordings to start playback.

4.2.4 Clipping Recording File

Clip a section Recorded Video File you do of 0 recorded video, and save it to PC message.

Step 6 On the **Search** interface, select **Mode**, **Date**, and **Record Type** for concentration playback. The corresponding search result is displayed.

Step 1 Select a playback window.

Step 2 Capture the video segment you need through the following methods:

- Enter the start time and end time you need to edit in .

- Click , and video clipping frame appears on the time bar. See Figure 4-8. Press the record edit column (the white column on) and drag to the left or right, to select start time and end time of clipping.

Figure 4-8 Video clipping frame



Step 3 Click  to select save path.

Step 4 Click **OK**.

The system begins to save the record file and displays the saving progress.



Click  to stop downloading the recordings.

4.3 Alarm Info

You can view the alarm information during a fixed period.

Step 1 On the main WEB interface, click **Alarm > Alarm Info**.

The **Alarm Info** interface is displayed. See Figure 4-9.

Figure 4-9 Alarm info (1)

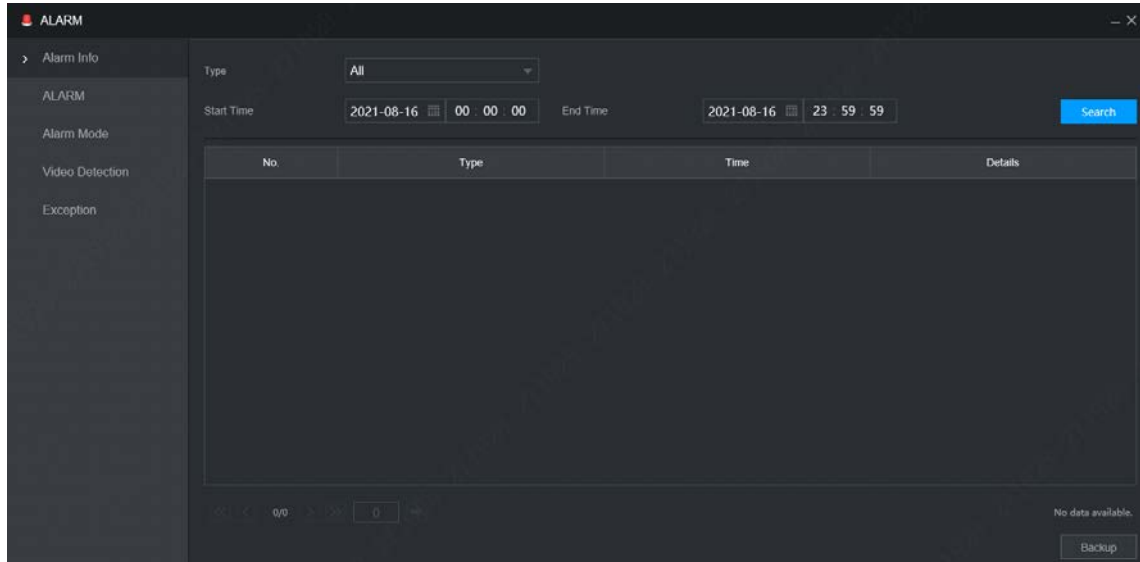

Step 2 Select **Type** to set the alarm type to be searched for, including **All, Motion Detection, Video Loss, Tampering, Exception, Local Alarm** and **Intelligent**.

Step 3 Enter the start time and end time.

Step 4 Click **Search**.

Alarm information in the set type during the set period is displayed. See Figure 4-10.

Figure 4-10 Alarm info (2)

No.	Type	Time	Details
1	HDD	2021-08-18 20:59:53	
2	HDD	2021-08-18 20:59:53	
3	HDD	2021-08-18 20:59:53	
4	Turnover	2021-08-18 20:58:45	
5	Turnover	2021-08-18 20:58:39	
6	HDD	2021-08-18 20:46:40	
7	HDD	2021-08-18 20:39:47	
8	Turnover	2021-08-18 19:45:18	
9	Turnover	2021-08-18 16:24:46	
10	IP Conflicted	2021-08-18 14:31:50	
11	IP Conflicted	2021-08-18 14:31:14	

1/1 Display 1 - 11, Total 11 Backup

Step 5 Click **Backup** to back up the obtained alarm information to a local directory.



You need to install relevant controls before backup.

5 System Settings

You can set up system information following instructions on the Local interface or WEB interface. This section introduces the WEB interface instructions. The **Local** interface is similar and would not be elaborated here.



- Some functions can only be configured on the **Local** interface. The actual interface shall prevail.
- Some functions are not used in actual operations, so they are not described in detail in the document.
- In this section, when you have configured the settings for a channel, click **Copy to** apply the settings to other channels. Click **Refresh** to display the latest configuration. Click **Default** to restore to factory default settings.

5.1 Configuring Alarm Events

Alarm information settings include the setting of video detection, video alarm input and abnormality.

5.1.1 Video Detection

Video detection includes motion detection, video loss and tampering. This function detects the abnormal changes and triggers alarms.

5.1.1.1 Video Motion

When the moving object appears and moves fast enough to achieve the preset sensitivity value, the system triggers an alarm and alarm linkage.

Step 1 On the main WEB interface, select **Alarm > Video Detection > Motion Detect**.

The **Motion Detect** interface is displayed. See Figure 5-1.

Figure 5-1 Motion Detect

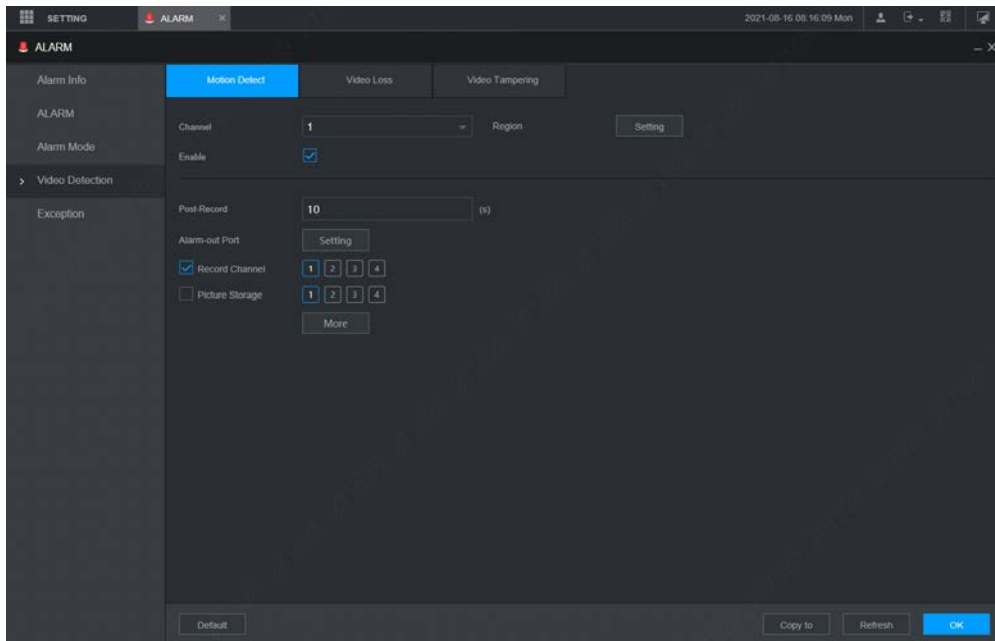

Step 2 Select the channel number and select **Enable** to enable the motion detection for the channel.

Step 3 Set motion detection region.

1) Next to **Region**, click **Setting**.

The **Setting** interface is displayed. See Figure 5-2.

Figure 5-2 Setting

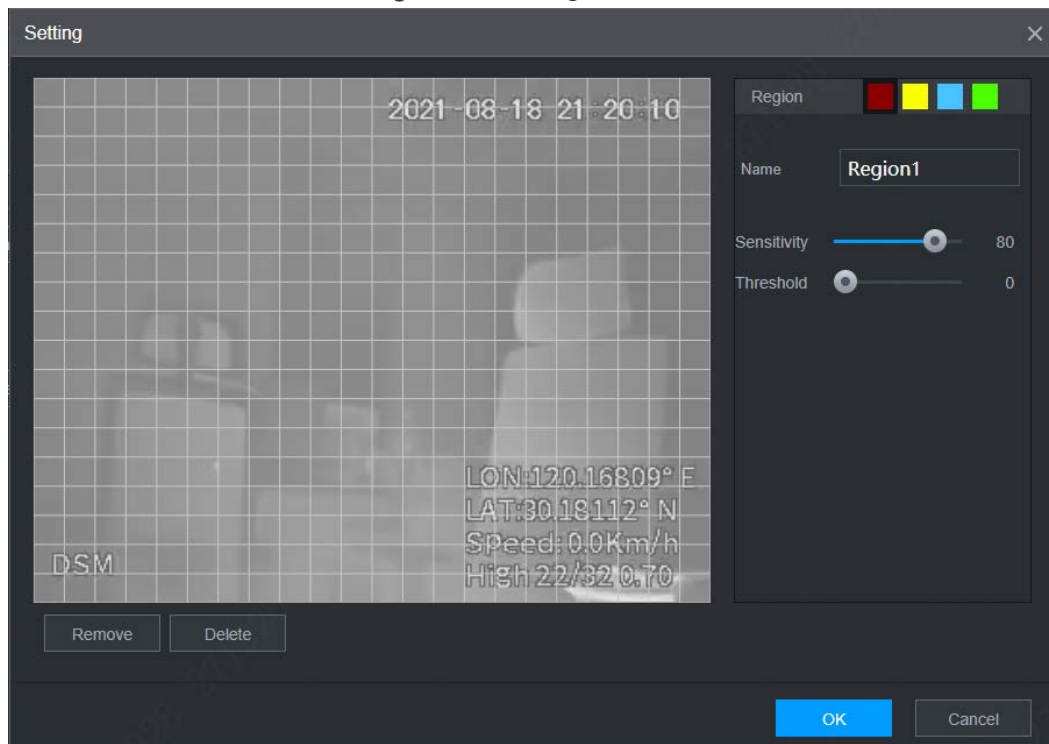

2) The higher the sensitivity value is, the easier the motion detection is triggered; the lower the threshold is, the easier the motion detect is triggered. By default, the whole video image is for motion detect.



Each color represents different region and you can define different motion detection areas for each region.

- 3) Hold down the left button of the mouse, drag to select the region to be detected, and set up its sensitivity and threshold value.





Channel alarm events: As long as any one of the four regions triggers alarm, the channel that houses the region will give alarm.

- 4) Click **OK** to finish configuration.

Step 4 Configure alarm linkage parameters. See Table 5-1 for details.

Table 5-1 Relay activation parameter description

Parameter	Description
Post-Record	The record keeps running for the defined time after alarm is ended.
Record Channel	Select the Record Channel check box and select a record channel(s), when an alarm event occurs, the corresponding channel starts recording automatically.  Two more conditions must be satisfied before alarm recording function works: <ul style="list-style-type: none"> • The motion detection recording is enabled. For details, see "3.7.1 Record." • The auto recording is enabled. For details, see "3.6 Configuring Record Mode."
Anti-dither	Click More to set the anti-dither time. The system records only one event during this period.
Log	Click More , and select the corresponding check box to enable the device to create a local alarm log when an alarm event occurs.
Send Email	Click More , and select the corresponding check box. When an alarm event occurs, the system sends email to the specified mailbox.  Set your e-mail first before enabling this function. See "5.5.4 Email" for detailed operations.

Step 5 Click **OK**.

5.1.1.2 Video Loss

When video loss occurs, the system triggers an alarm and configured actions.

Step 1 On the main WEB interface, select **Alarm > Video Detection > Video Loss**.

The **Video Loss** interface is displayed. See Figure 5-3.

Figure 5-3 Video Loss

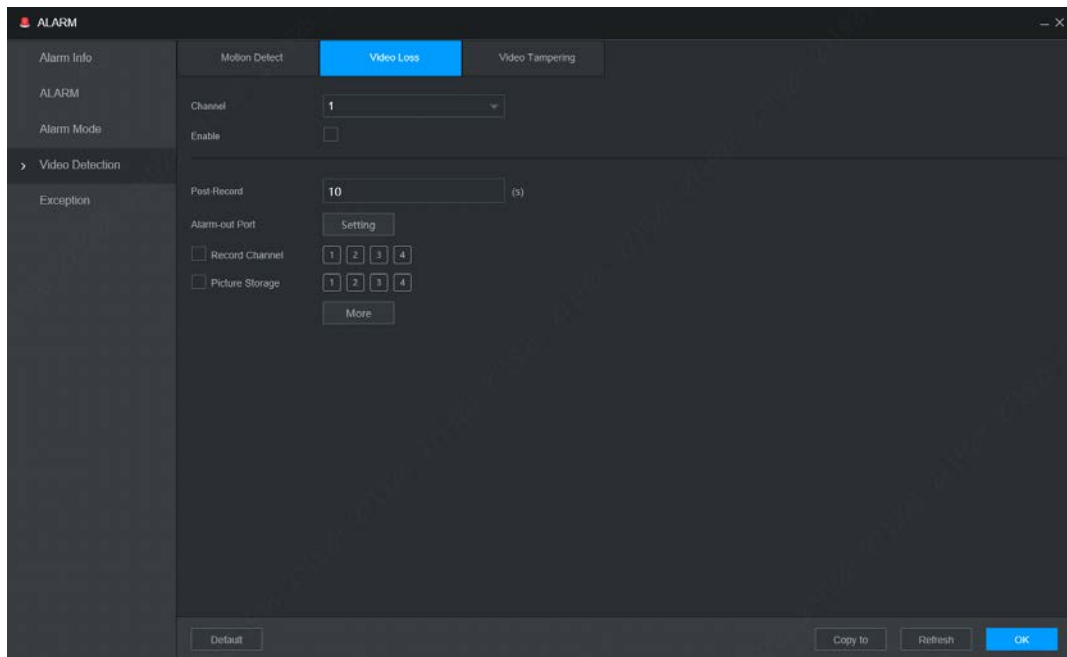

- Step 2 Select **Channel** and select **Enable** to enable the video loss detection for the channel.
- Step 3 Configure alarm linkage parameters. See Table 5-1 for details.
- Step 4 Click **OK**.

5.1.1.3 Video Tampering

When the camera lens is covered, or the video is displayed in a single color because of the causes such as sunlight status, the monitoring cannot be continued normally, and in this case, the system activates alarm and links the configured actions.

- Step 1 On the main WEB interface, select **Alarm > Video Detection > Video Tampering**. The **Video Tampering** interface is displayed. See Figure 5-4.

Figure 5-4 Video tampering

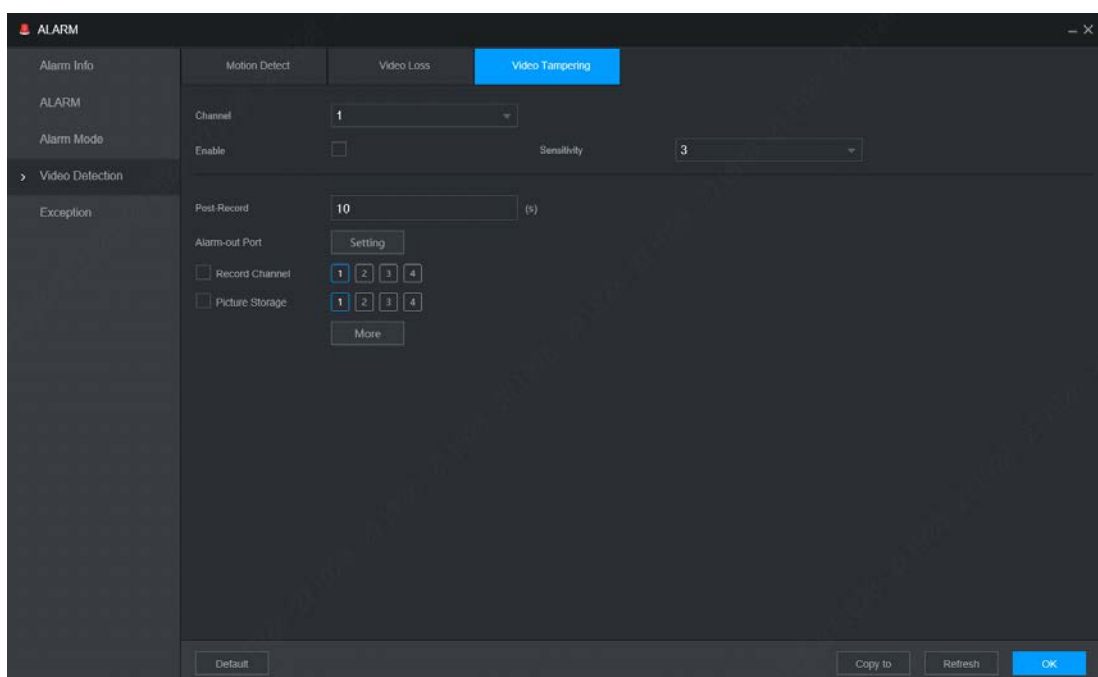

- Step 2** Select **Channel** and select **Enable** to enable the video tampering detection for the channel.
- Step 3** Set the sensitivity of detection.
The higher the sensitivity, the easier it is to detect a moving object, but the false alarm rate might increase.
- Step 4** Configure alarm linkage parameters. See Table 5-1 for details.
- Step 5** Click **OK**.

5.1.2 Alarm Input

Select different types of input according to alarm sources and set alarm output mode.

- Step 1** On the main **WEB** interface, select **Alarm > Alarm**.

The **Alarm** interface is displayed. See Figure 5-5.

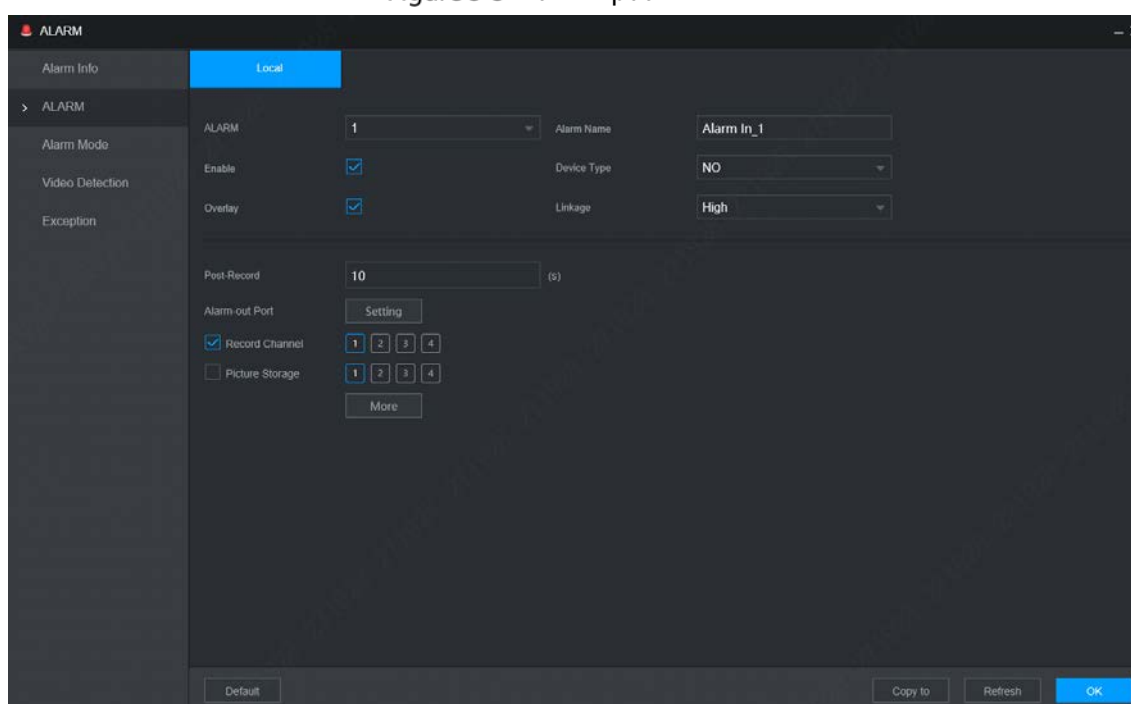

Figure 5-5 Alarm input



- Step 2** Local Alarm: The alarm signal detected by the alarm input port on the device.
- Step 3** Select the channel number and select **Enable**.
- Step 4** Configure parameters. For details, see Table 5-2.

Table 5-2 Alarm parameters description

Parameter	Description
Alarm Name	Enter a customized alarm name.
Device Type	If the Event Type is Local Alarm , configure this parameter. <ul style="list-style-type: none"> ● NO: The alarm signal is disconnected normally. The alarm is triggered when alarm signal is connected. ● NC: The alarm signal is connected normally. The alarm is canceled when alarm signal is disconnected.
Overlay	Select the Overlay check box to overlay alarm names onto channel images.

Parameter	Description
Linkage	If the Event Type is Local Alarm , configure this parameter. If the alarm signal is 12V/24V voltage, select High as the triggering mode; if the alarm signal is ground voltage, select Low as the triggering mode.
Record Channel	Select the Record Channel check box and select a record channel(s), when an alarm event occurs, the corresponding channel starts recording automatically.  Two more conditions must be satisfied before alarm recording function works: <ul style="list-style-type: none"> • The recording for alarm is enabled. For details, see "3.7.1 Record." • The auto recording is enabled. For details, see "3.6 Configuring Record Mode."
Post-Record	The video recording will not stop until the record delay time you set has passed.
Picture Storage	Select the corresponding check box and set the channel. When an alarm event occurs, the corresponding channel starts capturing automatically.  You can also configure the frequency, size, and quality of snapshot. For details, see "5.4.2.2 Snapshot."
Anti-dither	Click More to set the anti-dither time. The system records only one alarm input event during this period.
Log	Click More , and select the corresponding check box to enable the device to create a local alarm log when an alarm event occurs.
Send Email	Click More , and select the corresponding check box. When an alarm event occurs, the system sends email to the specified mailbox.  Set your e-mail first before enabling this function. See "5.5.4 Email" for detailed operations.

Step 5 Click **OK**.

5.1.3 Exception

You can configure the ways to handle the device when errors occur.

Step 1 On the main **WEB** interface, select **Alarm > Exception**.

The **Exception** interface is displayed. See Figure 5-6.

Figure 5-6 Exception

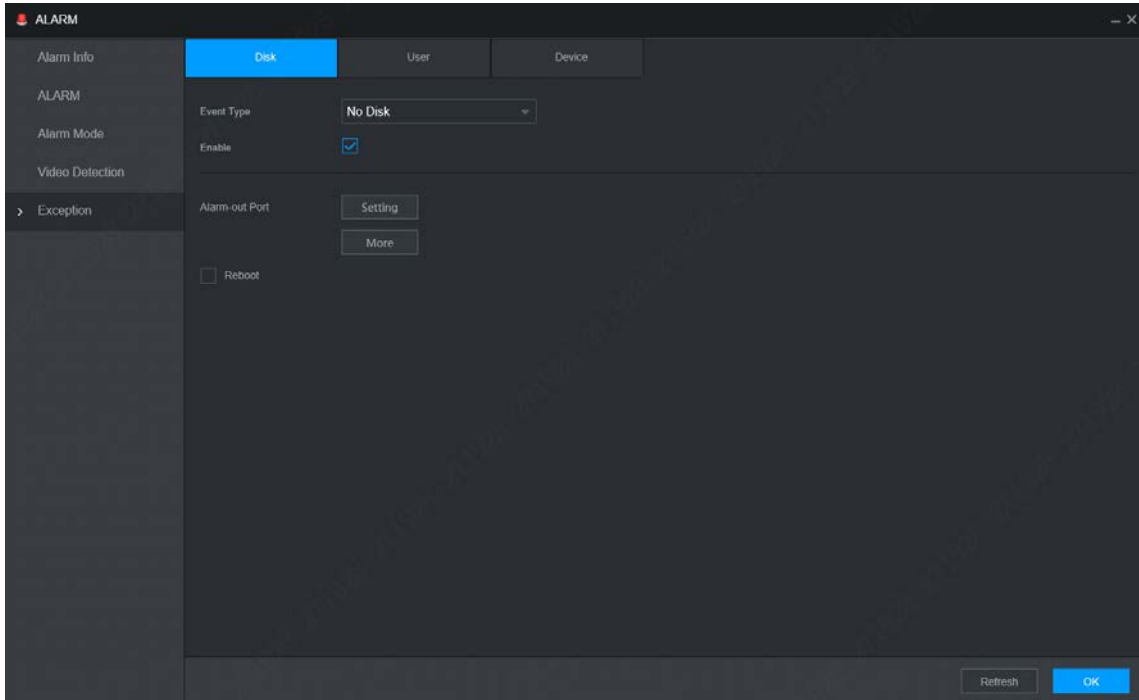

Step 2 Select the event type, and select **Enable** to enable the handling of corresponding abnormal events.

Step 3 Configure parameters. For details, see Table 5-3.

Table 5-3 Abnormal event parameters description

Parameter	Description
Event Type	<p>You can configure the corresponding abnormal events on following three tabs.</p> <ul style="list-style-type: none"> ● HDD: To set the ways to handle abnormal HDD events, including No Disk, HDD Error, Low Space. ● User: Includes illegal login. ● Device: To set the ways to handle abnormal device events, including Temperature Too High, Low Battery Safety Exception, Network Security Exception, Over Speed, Low Speed, Collision, and Rollover. <p> The supported event type might be different depending on the model you purchased, and the actual interface shall prevail.</p>
Low Than	Select Disk tab, and if the Event Type is Low Space , configure this parameter. You can set the percentage of HDD remaining space. When HDD remaining space is lower than this percentage, an alarm will occur.
Attempt(s)	If the Event Type is Illegal Login , configure this parameter. The maximum number of allowed password input errors during user login. If the number of password input errors reaches this value, the user account will be locked.
Lock Time	If the Event Type is Illegal Login , configure this parameter. If the number of password input errors reaches this value, the user account will be locked.

Parameter	Description
Max Temperature	If the Event Type is High Temperature , configure this parameter. Enter the upper limit of device temperature. The alarm is triggered when the device temperature exceeds this value.
Low Than	If Event Type is Battery Low Space , configure this parameter. The supply voltage to the device from the vehicle and the percentage of available supply voltage capacity. When the vehicle is in ACC Off, and the voltage supplied to the device is less than the percentage of available capacity, the system triggers an alarm.
Auto	
Battery Voltage	
Max Speed	If the Event Type is Over Speed , configure this parameter. The upper limit of vehicle speed. When the vehicle speed exceeds this value, the system triggers an alarm.
Min Speed	If Event Type is Low Speed , configure this parameter. The lowest limit of vehicle speed. When the vehicle speed is lower than this value, the system triggers an alarm.
Send Email	Click More , and select the corresponding check box. When an alarm event occurs, the system sends email to the specified mailbox.  Set your e-mail first before enabling this function. See "5.5.4 Email" for detailed operations.
Log Information	Click More , and select the corresponding check box to enable the device to create a local alarm log when an alarm event occurs.
Auto Reboot	Select the Reboot check box. If No HDD alarm occurs, the system restarts within three minutes.

Step 4 Click **OK**.

5.2 Configuring AI Plan

AI solution mainly contains active and safe drive. Only when the smart solution is enabled and set can the corresponding function take effect.

- ADAS: Advanced Driver Assistance System for detecting Lane Departure, Vehicles Too Close and Vehicle Collision pre-warnings, and alarm linkage is triggered and reported to the platform.
- DSM: The system can analyze and process the driver behavior information collected by cameras, and detect actions such as lowering head, yawning, smoking, looking around, and leaving position.
- Left items recognition: The function of left items recognition can intelligently identify items left in the rear seat, alert when items are detected and upload the platform.



- You can enable up to three smart functions at the same time.
- The camera installation takes some models as the examples, and the actual model shall prevail.

5.2.1 Configuring ADAS

ADAS alarms mainly include Forward Collision Warning, Lane Departure Warning and Headway Monitoring Warning.

Front-view smart function includes green light reminder, ahead car move reminder, speed limit reminder and yielding to pedestrian reminder.



Access to cornering lamp signal in advance: Alarm Input_2 (turn left), Alarm Input_3 (turn right).

After the cornering lamp of the vehicle is turned on, no Lane Departure alarm will be triggered.

Step 1 On the main **WEB** interface, click **AI > Parameters > ADAS**.

The **ADAS** interface is displayed. See Figure 5-7.

Figure 5-7 ADAS

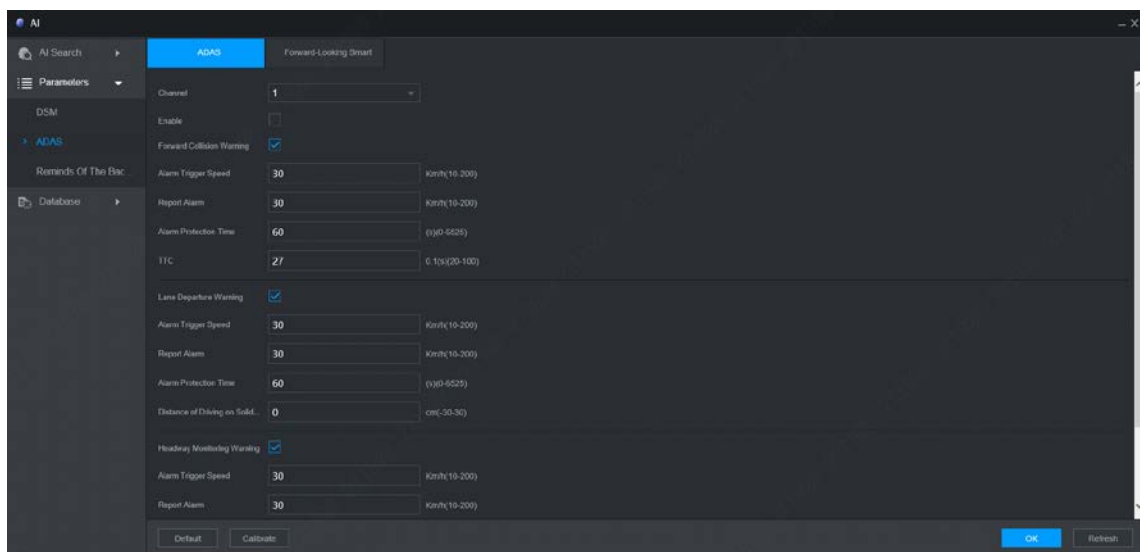

Step 2 Click **Enable** and **OK** to enable the ADAS alarm.

Step 3 Click **Calibrate**.

Step 4 The **Calibrate** interface is displayed. See Figure 5-8.



- Driver assistance relies on the camera installation location, and cannot be used until the calibration is completed. Try to install the camera in the middle of the windshield. When configuring parameters, measure the width of the vehicle, the height of the camera, and the distance from the camera to the vehicle head in advance. After the vehicle travels for a certain period of time, the device will automatically calibrate the position.
- The X value represents the installation yaw angle of the camera, and the range is 2958-5233; The Y value represents the installation pitch angle of the camera, and the range is 3872-4320. If the parameters exceed the above range, the system will judge that the camera installation angle is unreasonable and the calibration fails.

Figure 5-8 Calibrate

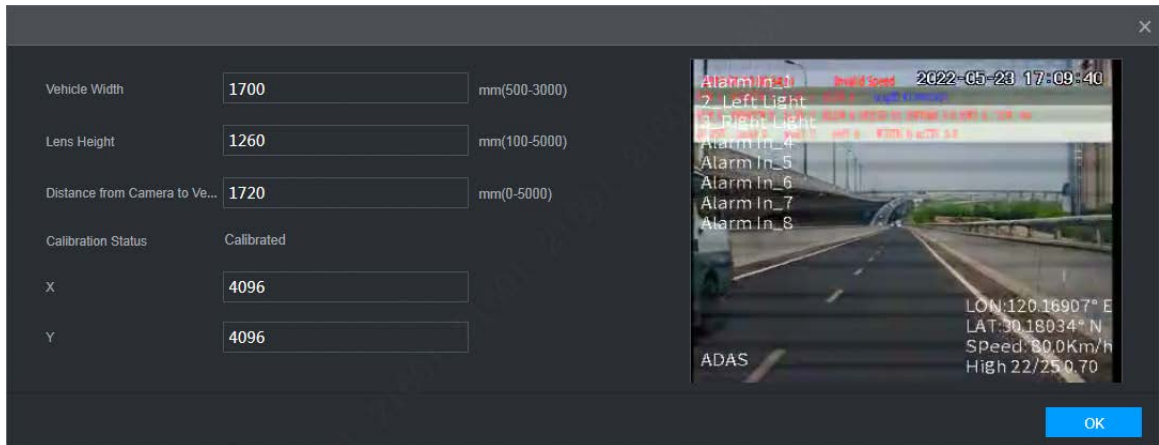

Step 5 Enter the vehicle width, the lens height and the distance from the camera to the vehicle head, and click **OK** to complete the calibration.

Step 6 Click  to return to the Figure 5-8 interface.

Step 7 Configure parameters. For details, see Table 5-4.



means the corresponding alarm is enabled.

Table 5-4 ADAS parameter description

Parameter	Description
Channel	ADAS is fixed to channel 1.
Forward Collision Warning	Give a warning if it is possible to collide with the vehicle in the front.
Alarm Trigger Speed	The speed at which the Forward Collision Warning is triggered: The range is 10km/h–200km/h.
Report Alarm	The speed at which the Forward Collision Warning is uploaded: The range is 10km/h–200km/h.
Alarm Protection Time	Alarm interval time: The range is 0s–6525s.
TTC	Time to collision: The range is 2s–10s.
Lane Departure Warning	Alarm when the vehicle directly changes the lane without turning on the left or right cornering lamp.
Alarm Trigger Speed	The speed at which the Lane Departure Warning is triggered: The range is 10km/h–200km/h.
Report Alarm	The speed at which the Lane Departure Warning is uploaded: The range is 10km/h–200km/h.
Alarm Protection Time	Alarm interval time: The range is 0s–6525s.

Parameter	Description
Distance of Driving on Solid Line	Set the distance of driving on solid line: The range is -30cm-30cm.
Headway Monitoring Warning	Alarm when the vehicle is too close to the vehicle in the front.
Alarm Trigger Speed	The speed at which the Headway Monitoring Warning is triggered: The range is 10km/h-200km/h.
Report Alarm	The speed at which the Headway Monitoring Warning is uploaded: The range is 10km/h-200km/h.
Alarm Protection Time	Alarm interval time: The range is 0s-6525s.
Vichele Ahead Start	Remind when the front car starts from stopping.
Alarm Protection Time	Alarm interval time: The range is 0s-65536s.
TTC	Time to collision: The range is 1s-10s.

Step 8 Click **OK**.

5.2.2 Configuring DSM

DSM alarms mainly include drowsy driving, distracted driving, calling, no driver, wearing IR-blocking sunglasses, smoking, lens tampering, unbelted alarm. After being triggered, these alarms require voice broadcast and upload to the platform.

5.2.2.1 Installing DSM camera

Precautions

- The elevation angle range between the camera lens and the horizontal line below the face should be 10° ~ 30°, and the camera should be 80cm ~ 90cm away from the face.

Figure 5-9 Installation position



- When installing the camera, it is necessary to ensure that the face is in the picture. If the face is incomplete or not in the picture after bowing, the detection may be invalid.

Figure 5-10 Face in the picture

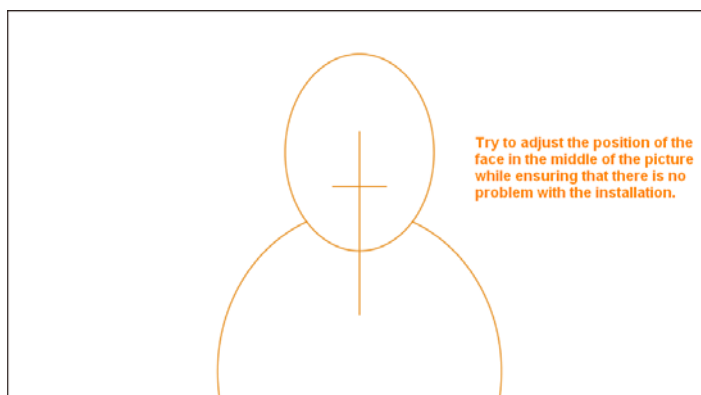

Procedure

- Step 1** Take out 3M glue from the equipment accessories and stick 3M glue to the camera base (the cable is led out from the side).
- Step 2** Paste the camera onto the mounting surface according to the monitoring position of the camera.

Figure 5-11 Installing camera (1)

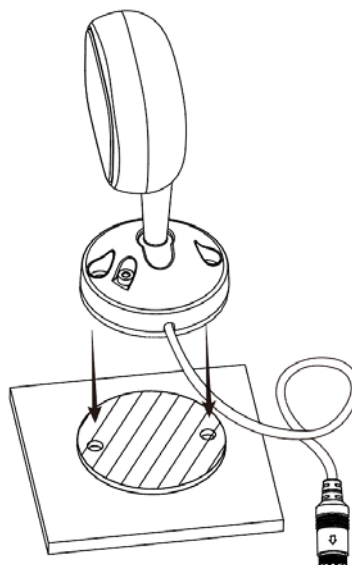

Step 3 Use PH2 screwdriver to insert two ST4 × 15 screws into the mounting hole.

Figure 5-12 Installing camera (2)

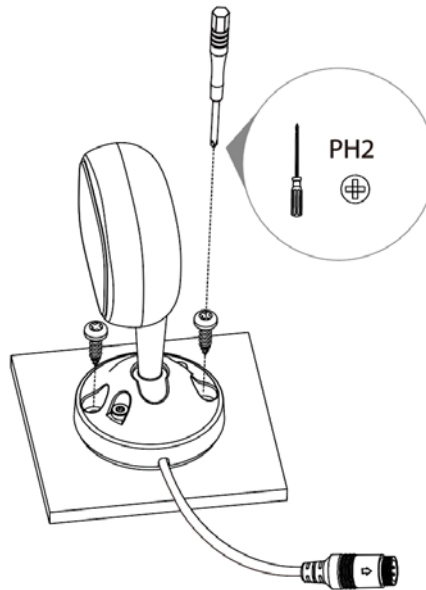

Step 4 Insert the self-tapping screw hole plug into the screw hole.

Figure 5-13 Installing camera (3)

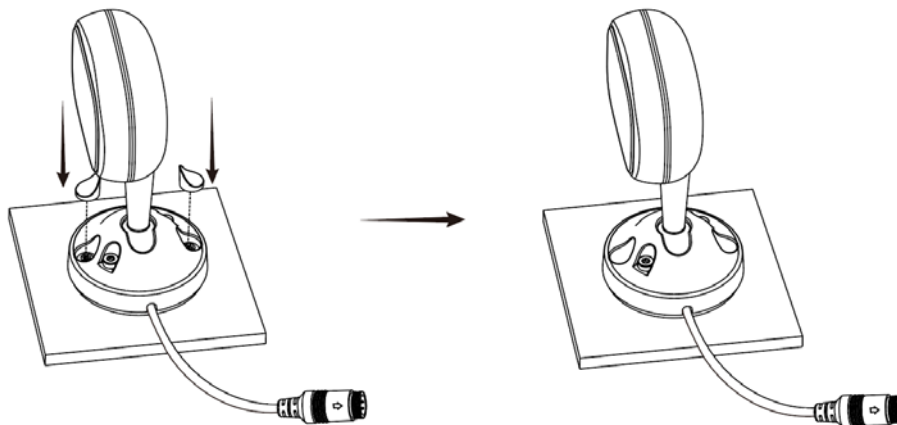

Adjusting angle

Step 1 Connect the cable to the DSM port of the dash camera.

Step 2 Use a T9 wrench to loosen the fixing screw of the camera ball joint rod.

Figure 5-14 Adjusting angle (1)

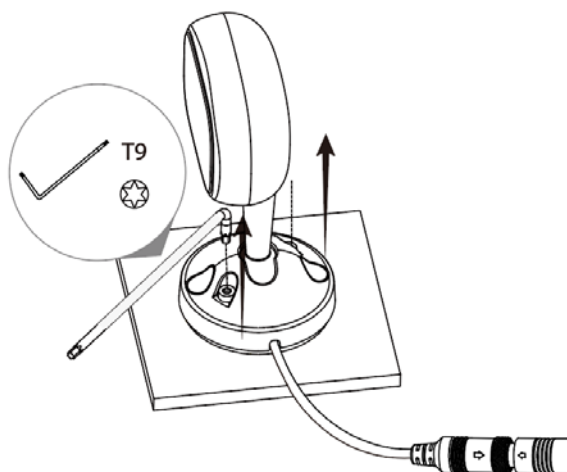

Step 3 After the image is displayed on the local display screen, adjust the lens angle to the appropriate monitoring position.

Figure 5-15 Adjusting angle (2)

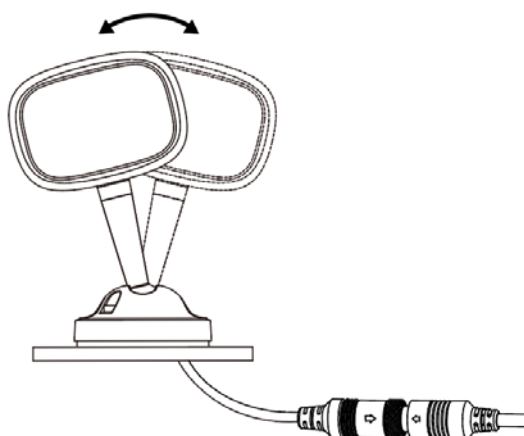

Step 4 Tighten the fixing screws of the camera ball joint rod. The installation is completed.

Figure 5-16 Adjusting angle (3)

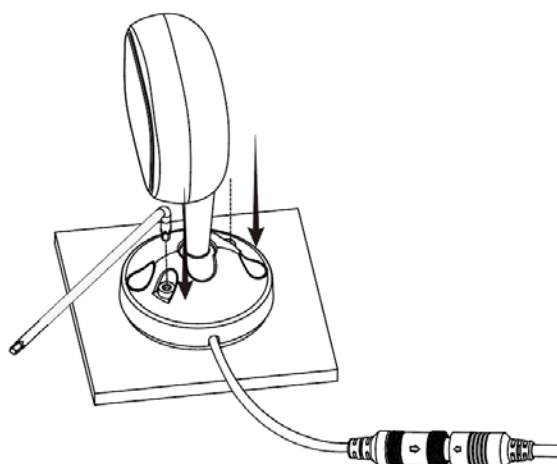

5.2.2.2 Configuring Parameters

Step 1 On the main **WEB** interface, click **AI > Parameters > DSM**.

The **DSM** interface is displayed. See Figure 5-17.

Figure 5-17 DSM

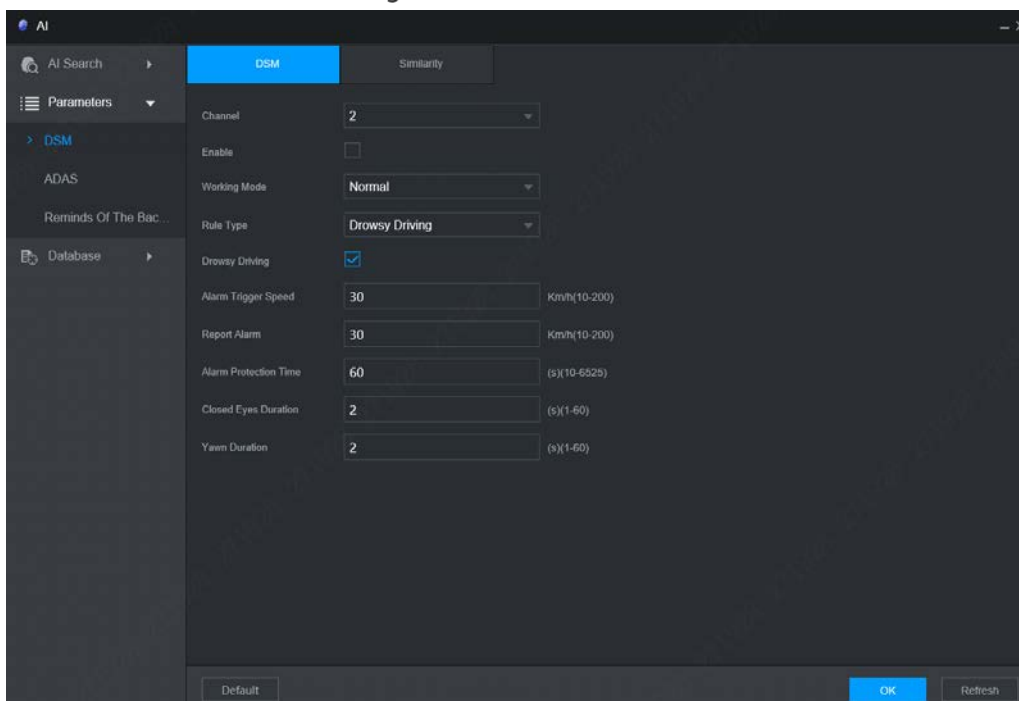

Step 2 Click **Enable** to enable the DSM alarm.

Step 3 Configure parameters. For details, see Table 5-5.

Table 5-5 DSM parameter description

Parameter	Description
Channel	The DSM is fixed to channel 2.
Working Mode	Vehicle working modes include normal mode and test mode.
Rule Type	For alarm rules, you can select drowsy driving, distracted driving, calling when driving, driver not in position, wearing infrared-blocking sunglasses, smoking when driving, camera being shielded and not wearing seat belt.  <input checked="" type="checkbox"/> means the corresponding alarm is enabled.
Alarm Trigger Speed	The speed at which the alarm is triggered: The range is 10km/h–200km/h.
Report Alarm	The speed at which the alarm is uploaded: The range is 10km/h–200km/h.
Alarm Protection Time	Time of alarm protection: The range is 10s–6525s.
Closed Eyes Duration	Setting is necessary when the rule type is Drowsy Driving : The range is 1s–60s.
Yawn Duration	
Lowering Head Duration	Setting is necessary when the rule type is Distracted Driving : The range is 1s–60s.
Looking around Duration	
Calling Duration	Setting is necessary when the rule type is Calling : The range is 1s–60s.

Parameter	Description
Duration without Driver	Setting is necessary when the rule type is No Driver : The range is 1s–60s.
Duration of Wearing IR Blocking Sunglasses	Setting is necessary when the rule type is Wearing IR Blocking Sunglasses : The range is 1s–60s.
Smoking Duration	Setting is necessary when the rule type is Smoking : The range is 1s–60s.
Tampering Duration	Setting is necessary when the rule type is Lens Tampering : The range is 1s–60s.
Not Wearing Seatbelt Duration	Setting is necessary when the rule type is Unbelted Alarm : The range is 1s–60s.

Step 4 Click **OK**.

5.2.3 Configuring Reminds of the Back Row

The function of left items recognition can intelligently identify items left in the rear seat, alert when items are detected and upload the platform.

Step 1 On the main WEB interface, click **AI > Parameters > Reminds of the Back Row**

The **Reminds of the Back Row** interface shown as Figure 5-18 is displayed.

Figure 5-18 Reminds of the Back Row

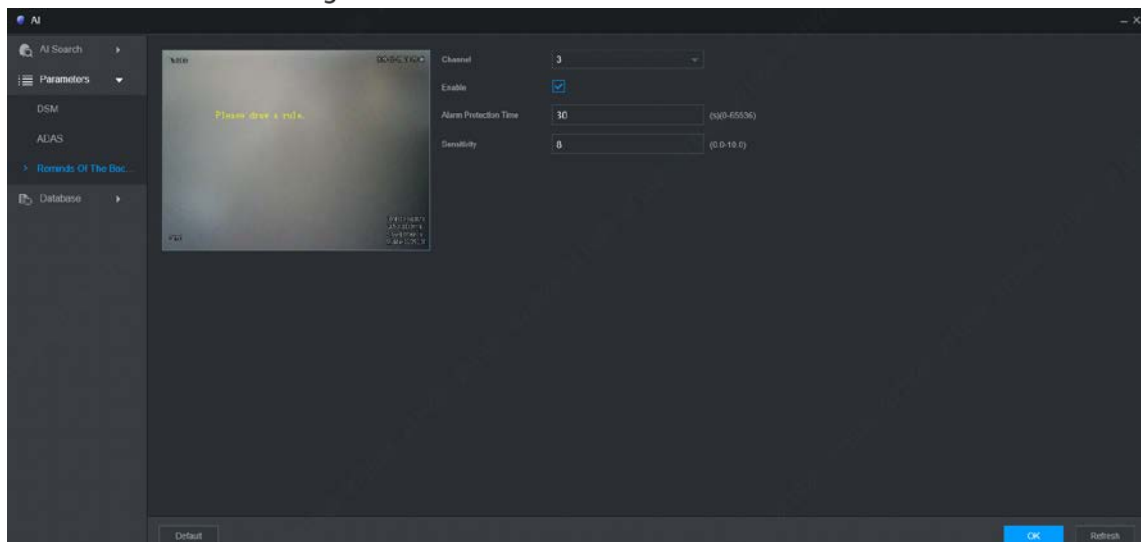

Step 2 Click **Enable**, “Please draw a rule” appears on the screen.

Step 3 Draw the area range which needs to be detected. See Figure 5-19.

Step 4 Click **OK**.

Figure 5-19 Area box of left items

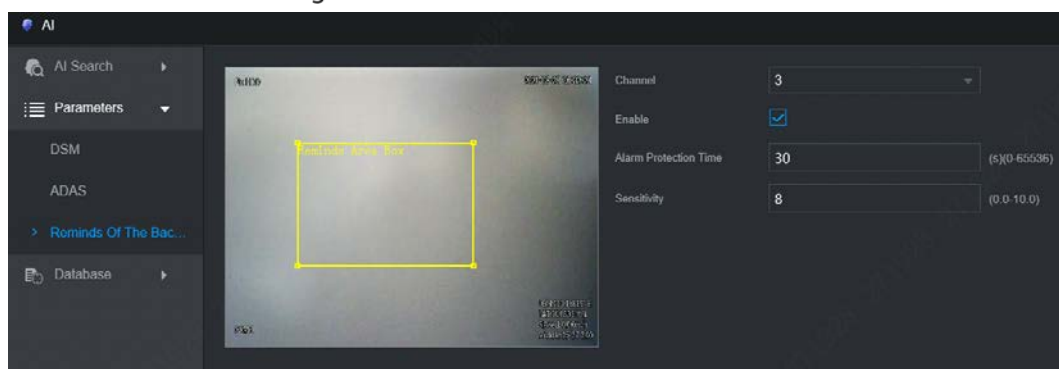

Select a channel from Channel 3 to Channel 4 to enable the detection.

5.2.4 AI Search

Users can set up search parameters and screen out specific alarm recordings for playback.

Step 1 On the main web interface, select **AI > AI Search**.

Select **DSM**, **ADAS** or **Reminds of the Back Row**.

Step 2 Select the channel, start time and end time.

Step 3 Click **Search**.

The search result is displayed.

5.3 File Backup

Configuring Backup of Video and Picture.

Step 1 On the main **WEB** interface, click **Backup**.

The **Backup** interface is displayed. See Figure 5-20.

Figure 5-20 Backup (1)

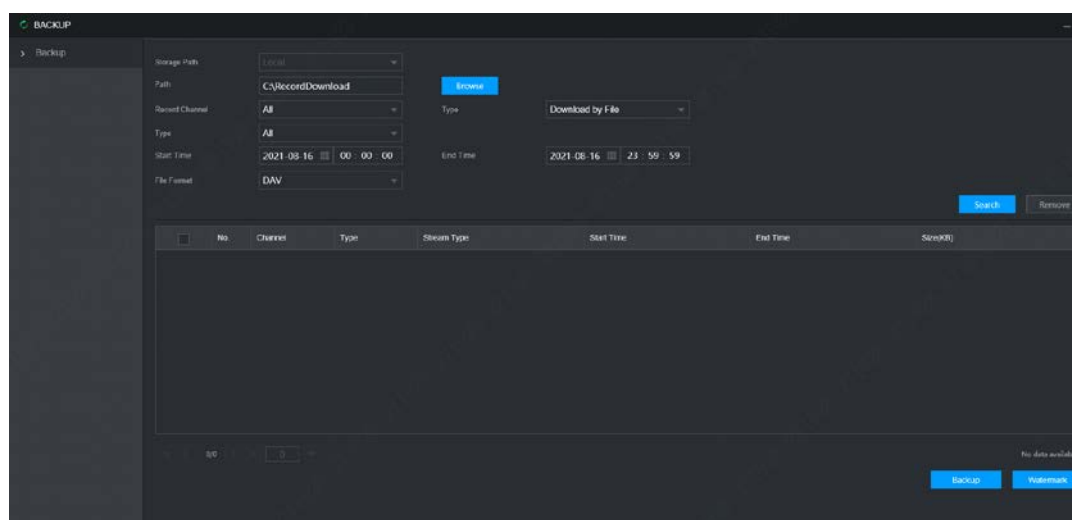

Step 2 Configure parameters. For details, see Table 5-6.

Table 5-6 Backup parameters description

Parameters	Description
Storage Path	Only local address is supported.
Path	File backup path is C:/RecordDownload by default. Click Browse to set the backup path as needed.
Record Channel	Select the channel you want to back up.
Download Type	Select the backup type, including download by file and download by time.
Start Time	Set the file backup period.
End Time	
File Format	Select the backup file format, including DAV and MP4.
Recording Type	Select the record type, including All, Alarm, Motion, M&A, General and picture.

Step 3 Click **Search**.

The obtained files are displayed.

Step 4 Select the file that you want to back up, and click **Backup**.

The **Backup** button is changed to **View Download** now. See Figure 5-21.

Figure 5-21 Download

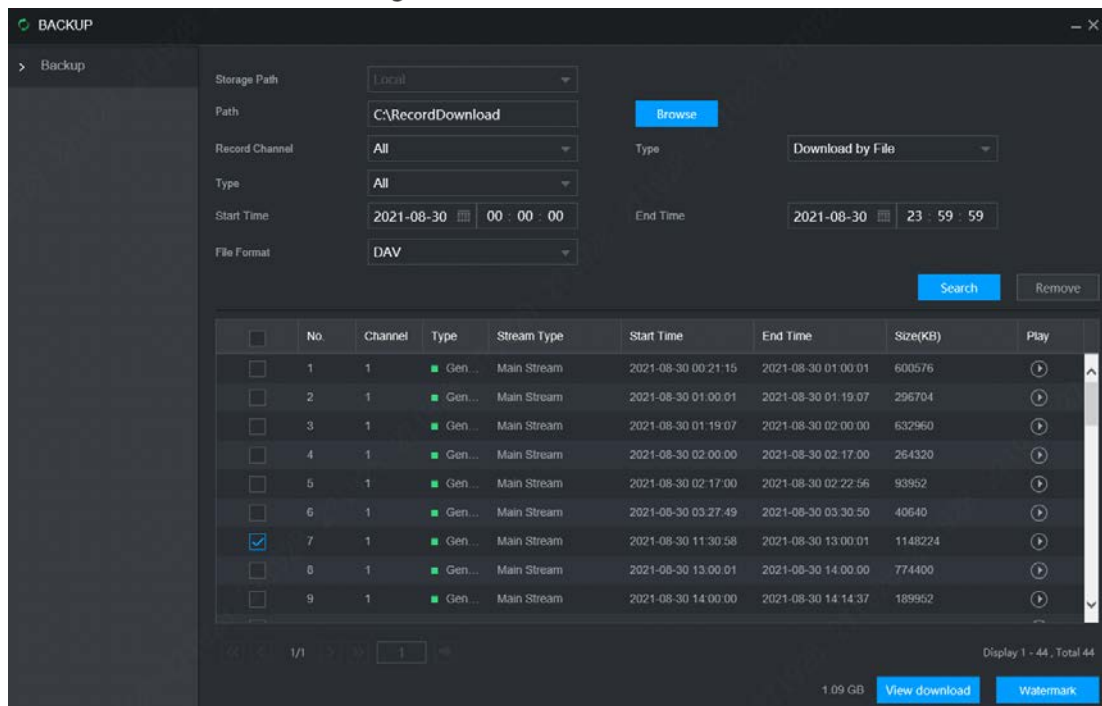

Step 5 Click View Download.

The **View Download** interface is displayed. See Figure 5-22.

Figure 5-22 View Download

Stop	No.	Channel	Start Time	End Time	Size(KB)	Status	Remaining Time
↓ STOP	1	1	2021-08-18 00:00:00	2021-08-18 01:00:00	68480	82%	00:00:01
↓ STOP	2	1	2021-08-18 01:00:00	2021-08-18 02:00:01	62208	0%	00:00:00
↓ STOP	3	1	2021-08-18 02:00:01	2021-08-18 03:00:01	62336	0%	00:00:00
↓ STOP	4	1	2021-08-18 03:00:01	2021-08-18 04:00:00	62336	0%	00:00:00
↓ STOP	5	1	2021-08-18 04:00:00	2021-08-18 05:00:02	62464	0%	00:00:00
↓ STOP	6	1	2021-08-18 05:00:02	2021-08-18 06:00:01	98688	0%	00:00:00
↓ STOP	7	1	2021-08-18 06:00:01	2021-08-18 07:00:00	129216	0%	00:00:00
↓ STOP	8	1	2021-08-18 07:00:00	2021-08-18 08:00:00	131264	0%	00:00:00
↓ STOP	9	1	2021-08-18 08:00:00	2021-08-18 09:00:01	129536	0%	00:00:00
↓ STOP	10	1	2021-08-18 09:00:01	2021-08-18 09:11:05	26880	0%	00:00:00
↓ STOP	11	1	2021-08-18 09:11:05	2021-08-18 10:00:01	125376	0%	00:00:00
↓ STOP	12	1	2021-08-18 10:00:01	2021-08-18 10:53:27	119296	0%	00:00:00



Click **Stop All** to stop downloading.

Step 6 (Optional) Select the file that you want to verify, and click **Watermark**.



Watermark can be used to verify whether the record file is falsified.

The verifying progress and result are displayed.

5.4 Configuring Camera Parameters

You can set camera properties and encode parameters.

5.4.1 Configuring Image Properties

You can set up the image property parameters of the channel.



Different cameras correspond to different property parameters. The actual parameters shall prevail.

Step 1 Select Setting > Camera > Image.

The **Image** interface is displayed. See Figure 5-23.

Figure 5-23 Image

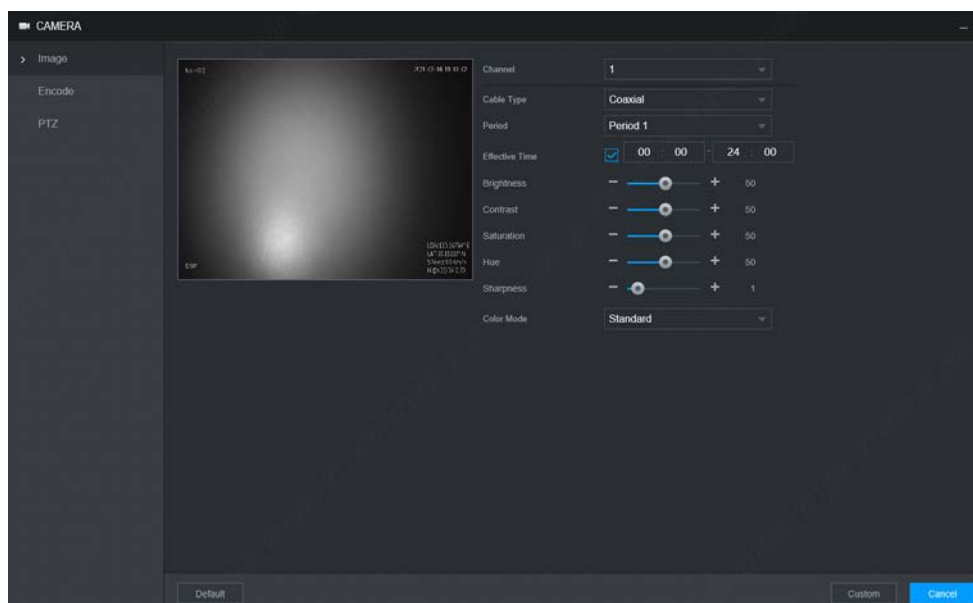

Step 2 Select a **Channel**.

Step 3 Configure parameters. For details, see Table 5-7.

Table 5-7 Image properties parameters description

Parameter	Description
Cable Type	The cable type is fixed to coaxial.
Period	Select the period. There are two Periods for you. You should set up the Effective Time for different periods.
Brightness	Adjusts the image brightness through linear mode. The bigger the value is, the brighter the image will become.
Contrast	Adjust the image contrast. The bigger the value is, the more obvious the contrast between the light area and dark area will become.
Saturation	Adjusts the color darkness. Adjust the saturation according to the actual situation. The bigger the value, the lighter the color of the image will become.
Hue	Adjusts the color hue. Adjust the hue according to the actual situation. The bigger the value, the colder the color of the image will become.
Sharpness	Set the sharpness of picture edges. The bigger the value is, the more obvious the image edge will become.
Hue	Adjusts the color darkness. Adjust the saturation according to the actual situation. The bigger the value, the lighter the color of the image will become.
Color Mode	Select the color mode. There are 5 preinstall modes you can choose, or you can set 4 custom modes for options. Preinstall modes includes Standard, Soft, Bright, Vivid, Bank.

Step 4 Click **OK**.

5.4.2 Encode Parameters

You can set **Encode**, **Snapshot**, **Overlay**, and **Storage Path**.

Configuring Video and Audio

You can configure the encode settings for main stream and sub stream.

Step 1 Select Setting > Camera > Encode > Audio/Video.

The **Audio/Video** interface is displayed. See Figure 5-24.



Encode parameters might be different depending on devices, and the actual product shall prevail.

Figure 5-24 Audio/Video

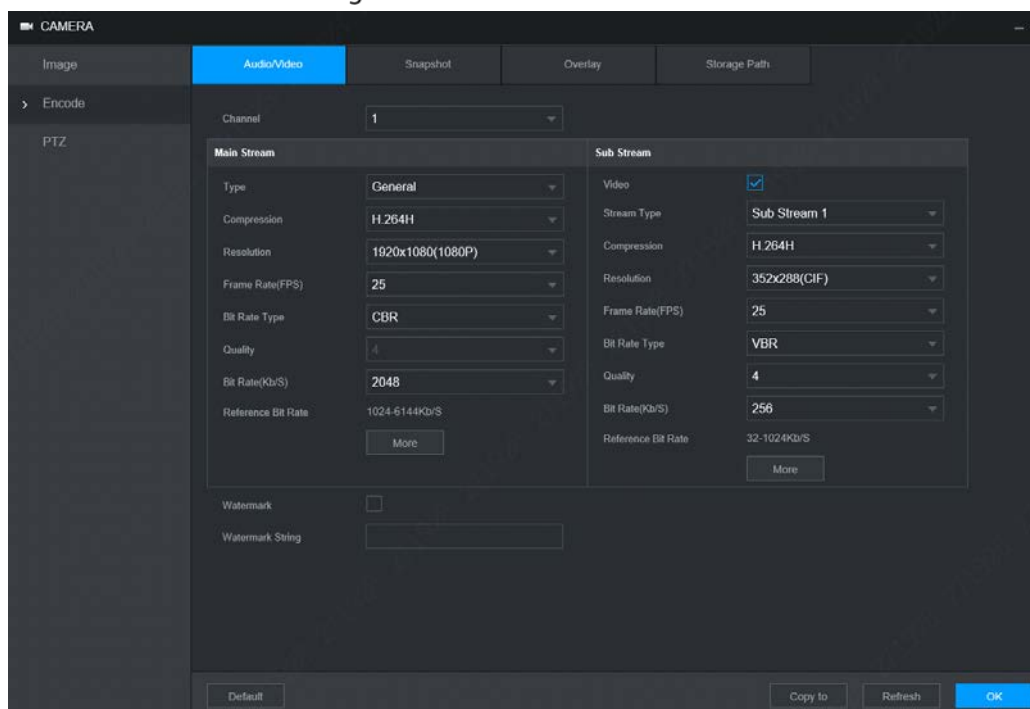



Step 2 Select a channel number.

Step 3 Configure parameters. For details, see Table 5-8.

Table 5-8 Stream parameters

Parameter	Description
Video	Enable the sub stream.
Type	The record type of main stream is permanently fixed as general and cannot be changed. General, motion detect and alarm use the general stream configurations for recording.
Stream Type	Sub stream types.
Compression	Encode mode of video.
Resolution	The higher the video resolution, the better the image quality.
Frame Rate (FPS)	Configure the frames per seconds for videos. The higher the value, the smoother and more vivid the image.

Parameter	Description
Bit Rate Type	<p>Select a control mode for bit rate of video.</p> <ul style="list-style-type: none"> ● CBR: The bit rate changes little and keeps close to the defined bit rate value. ● VBR (Variable Bit Rate): The bit rate changes along with environment.  <ul style="list-style-type: none"> ● It is recommended to select CBR when there might be only small changes in the monitoring environment, and select VBR when there might be big changes in the monitoring environment. ● The main stream is fixed to VBR.
Quality	<p>This parameter can be configured only when the Bit Rate Type is set as VBR.</p> <p>Select the image quality level. There are six levels in total. The higher the value, the better the image will become.</p>
Bit Rate(KB/S)	<p>Configure the encode value for main stream and sub stream.</p> <ul style="list-style-type: none"> ● When CBR is selected, select the bit rate according to the reference bit rate, and the bit rate changes along the configured value. ● When VBR is selected, select the upper limit value of bit rate according to the reference bit rate, and the bit rate changes along with the monitoring environment. But the maximum bit rate value changes around the configured value. ● Select Customized, and you can configure bit rate value manually.
Reference Bit Rate	<p>The system recommends the optimal bit rate range according to the resolution and frame rate settings.</p>
Audio Enable	<p>Click More to enable the audio.</p> <p>If the corresponding check box is selected, the video recordings are audio and video combined streams.</p>
Compression	<p>Select an audio encode format.</p>  <p>The parameters might be different depending on the model you purchased, and the actual product shall prevail.</p>
Audio Source	<p>Source of audio.</p>
Watermark	<p>Select the Watermark check box to verify whether the recorded video is falsified.</p>
Watermark String	<p>Enter the strings for verifying watermark. The default string is DigitalCCTV. You can configure at most 127 watermark characters which are composed of number, letter, underline and dash.</p>

Step 4 Click **OK**.

5.4.2.2 Snapshot

You can configure the snapshot settings such as snapshot type, image size, quality, and interval.

Step 1 Select Figure> Camera > Encode > Snapshot.

The **Snapshot** interface is displayed, see Figure 5-25.

Figure 5-25 Snapshot

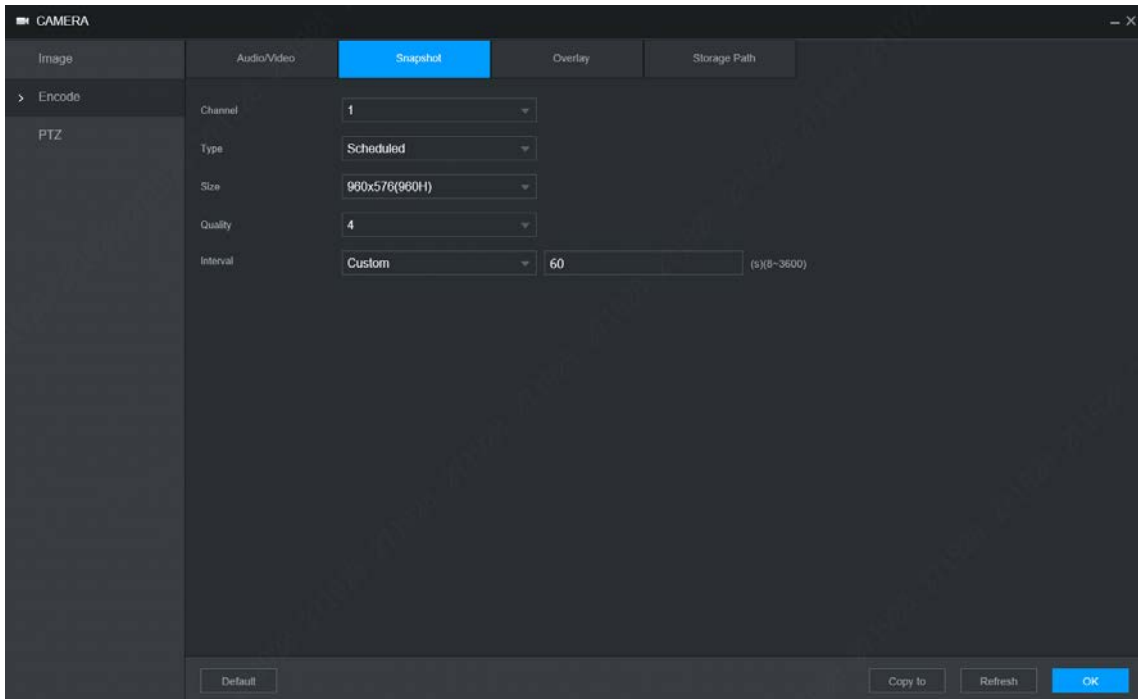

Step 2 Select **Channel**.

Step 3 Configure parameters. For details, see Table 5-9.

Table 5-9 Snapshot setting parameters description

Parameter	Description
Type	Includes scheduled and event. <ul style="list-style-type: none"> ● Schedule: Take snapshots within the configured period. ● Event: Take snapshots when alarms such as local alarm, video detection and abnormality are triggered.
Size	Select a resolution for the captured image.
Quality	The image quality and there are six levels in total.
Interval	Interval of taking snapshots. Select Custom to configure the snapshot interval for manually captured snapshots. The maximum value you can set is 3600 seconds as an interval between two snapshots.

Step 4 Click **OK**.

5.4.2.3 Overlay

You can configure to display the information such as system time and channel name on each channel window in the live view screen.

Step 1 Select Setting > Camera > Encode > Overlay.

The **Overlay** interface is displayed. See Figure 5-26.

Figure 5-26 Overlay

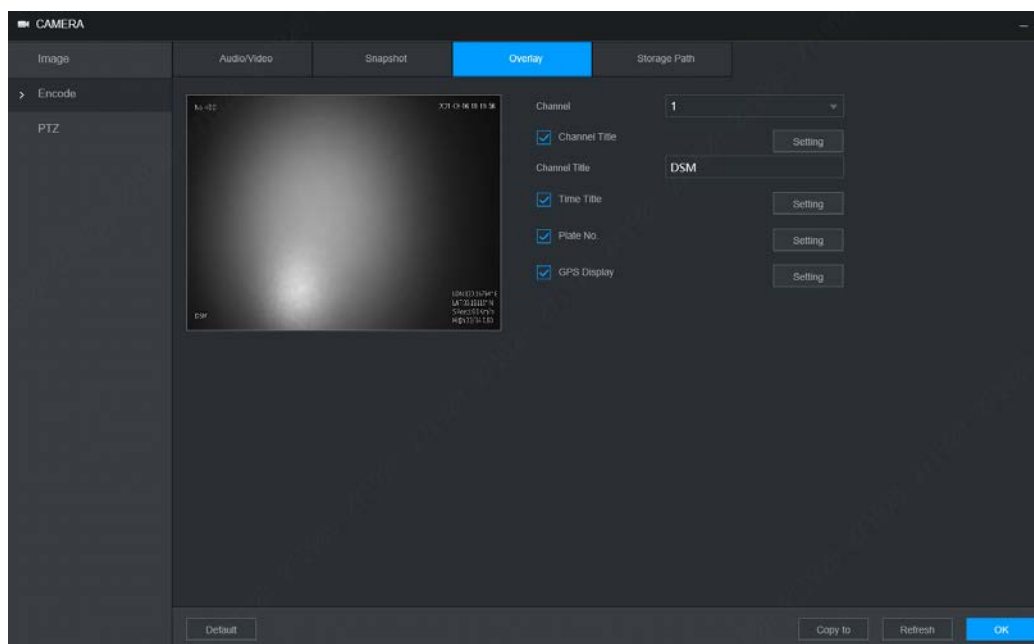

Step 2 Select **Channel**.

Step 3 Configure parameters. For details, see Table 5-10.

Table 5-10 Video overlay parameters description

Parameter	Description
Channel Title	Select Channel Title , and the Setting button is displayed. Then click Setting on the right of the Channel Title , enter the channel title, and drag it to a proper location.
Time Title	Select the Time Title check box, the Setting button is displayed. Then click Setting , the time is displayed on the channel window, and then drag it to a proper location.
Plate No	Select the Plate No check box, the Setting button is displayed. Then click Setting , the license number is displayed on the channel window, and then drag it to a proper location.
GPS Display	Select the GPS Display check box, the Setting button is displayed. Then click Setting , the GPS display frame is displayed on the channel window, and then drag it to a proper location.

Step 4 Click **OK**.

5.4.2.4 Storage Path



You can configure the storage path of captured snapshots and recorded videos.

Step 1 Select Setting > Camera > Encode > Storage Path.

The **Storage Path** interface is displayed. See Figure 5-27.

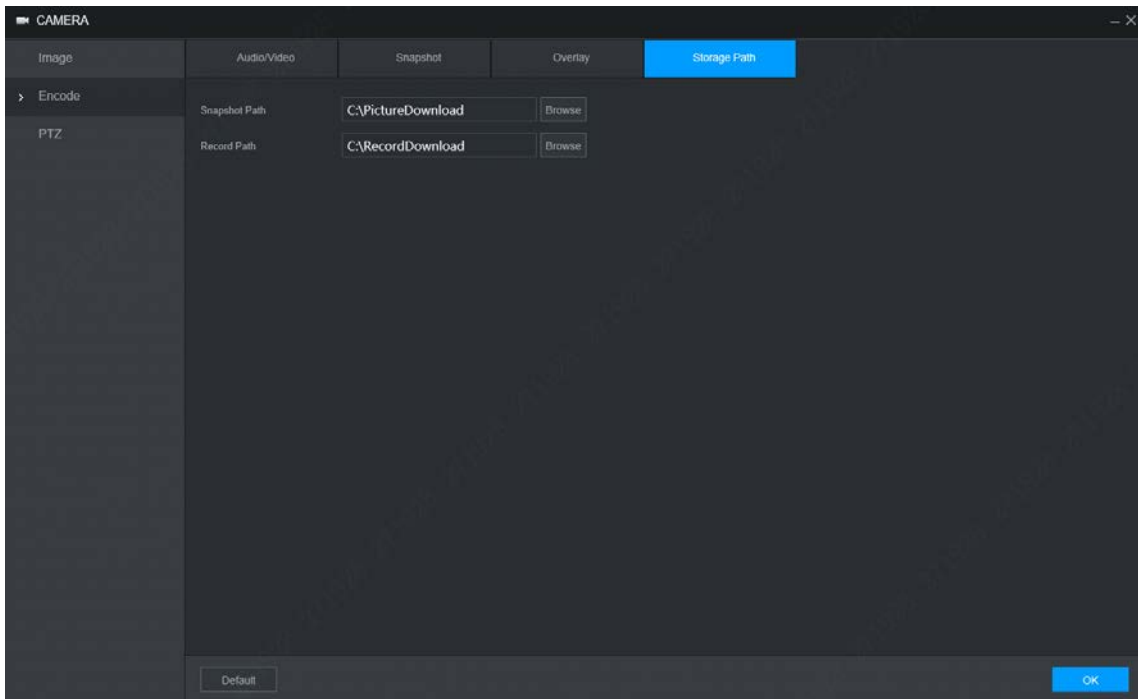
Figure 5-27 Storage path



Step 2 Click **Browse** to select the save path for snapshots and recordings. Images and recordings by using functions of snapshots  and recordings  on the **Live** interface are saved in these two paths by default. Default paths: C:\PictureDownload and C:\RecordDownload

Step 3 Click **OK**.

5.5 Configuring Network Parameters

You can set the network parameters of the device as needed, including ports, Wi-Fi parameters, 3G/4G parameters, Email, auto register.

5.5.1 Ports

Set each port value of the device.

Step 1 Select Setting > Network > Port.

The **Port** interface is displayed. See Figure 5-28.

Figure 5-28 Port

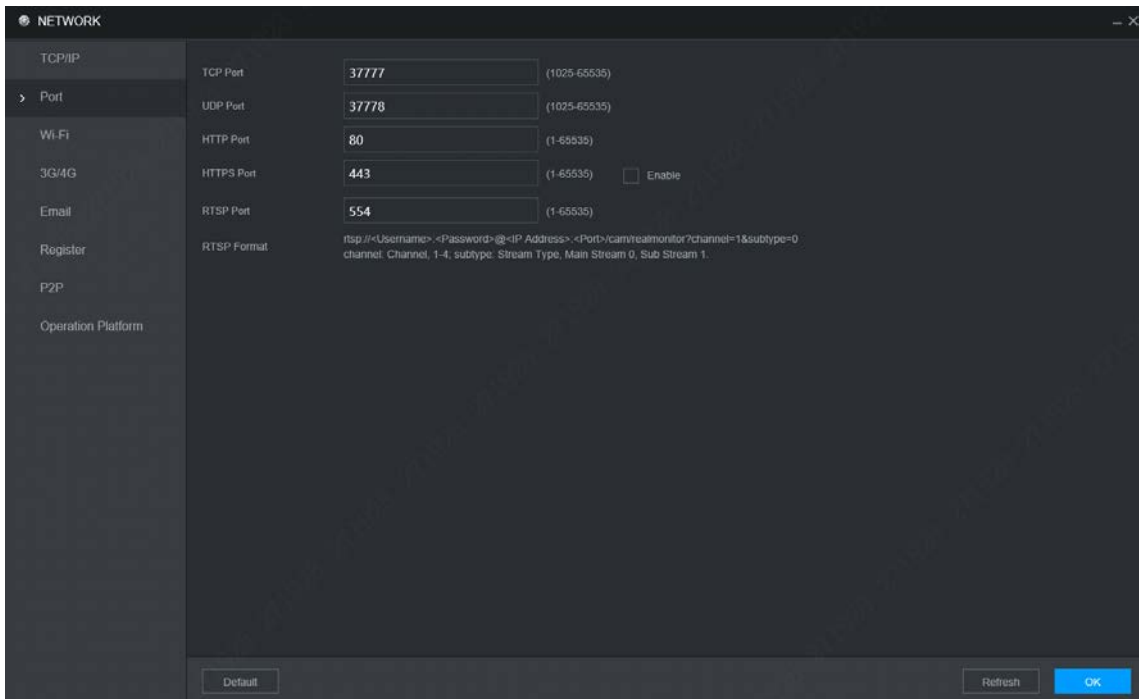

Step 2 Configure the ports of the device. For details, see Table 5-11.



The revised settings take effect after device restart. Proceed with caution.

Table 5-11 Port parameters description

Parameter	Description
TCP port	Transmission control protocol port. The value is 37777 by default.
UDP Port	User Datagram Protocol port. The default value setting is 37778. You can enter the value according to your actual situation.
HTTP Port	Hyper Text Transfer Protocol port. The default setting is 80. You can enter the value according to your actual situation, and in this case, please add the modified port number after the address when logging the device on the browser.
HTTPS Port	Hyper Text Transfer Protocol over Secure Socket Layer port. Select the Enable check box, and then enter the value as needed. The value is 443 by default.

Parameter	Description
RTSP Port	<p>Real Time Streaming Protocol port. Keep the default value 554 if it is displayed. If you play live view through Apple's QuickTime or VLC, the following format is available. This function is also available for Blackberry.</p> <p>When the URL format requiring RTSP, you need to specify channel number and bit stream type in the URL, and also user name and password if needed.</p> <p>When playing live view with Blackberry smart phone, you need to turn off the audio, and then set the code mode to H.264B and resolution to CIF.</p> <p>URL format example: rtsp://<User Name>:<Password>@<IP Address>:<Port>/cam/realmonitor?channel=1&subtype=0</p> <ul style="list-style-type: none"> ● User name. For example: admin. ● Password: For example: admin_123. ● IP address: For example, 192.168.1.16. ● Port: The default setting is 554. If the default setting is displayed, you do not need to configure this parameter. ● Channel: Numbers from 1. For example, if it is channel 2, then enter channel=2. ● Subtype: stream type. The main stream is 0 (subtype=0); the sub stream is 1 (subtype=1). <p>For example, if you require the sub stream of channel 2 from a device, then the URL shall be: rtsp://admin:admin_123@192.168.1.16:554/cam/realmonitor?channel=2&subtype=1</p> <p>If certification is not required, you do not need to specify the user name and password: Use the following format: rtsp://<IP Address>:<Port>/cam/realmonitor?channel=1&subtype=0</p>

Step 3 Click **OK**.

5.5.2 Wireless Network

You can connect the device to a network through Wi-Fi. Make sure the device can communicate with other devices in the group network. The device itself can also act as a hot spot to share flows with other terminals.



If both 3G/4G and Wi-Fi are available, the device connects to Wi-Fi and disconnects from 3G/4G.

5.5.2.1 Wi-Fi

You can connect the device to a network through Wi-Fi. Then connect the PC to the same network. You can log in to the WEB interface by PC to operate the device.



This function is only supported on the device with a Wi-Fi module. The actual situation shall prevail.

Prerequisites

Make sure that the device is connected to a Wi-Fi module.

Procedure

Step 1 Select Setting > Network > Wi-Fi.

The **Wi-Fi** interface is displayed.

Step 2 Select **Wi-Fi** as the working mode.

The **Wi-Fi** interface is displayed, see Figure 5-29.

Figure 5-29 Wi-Fi

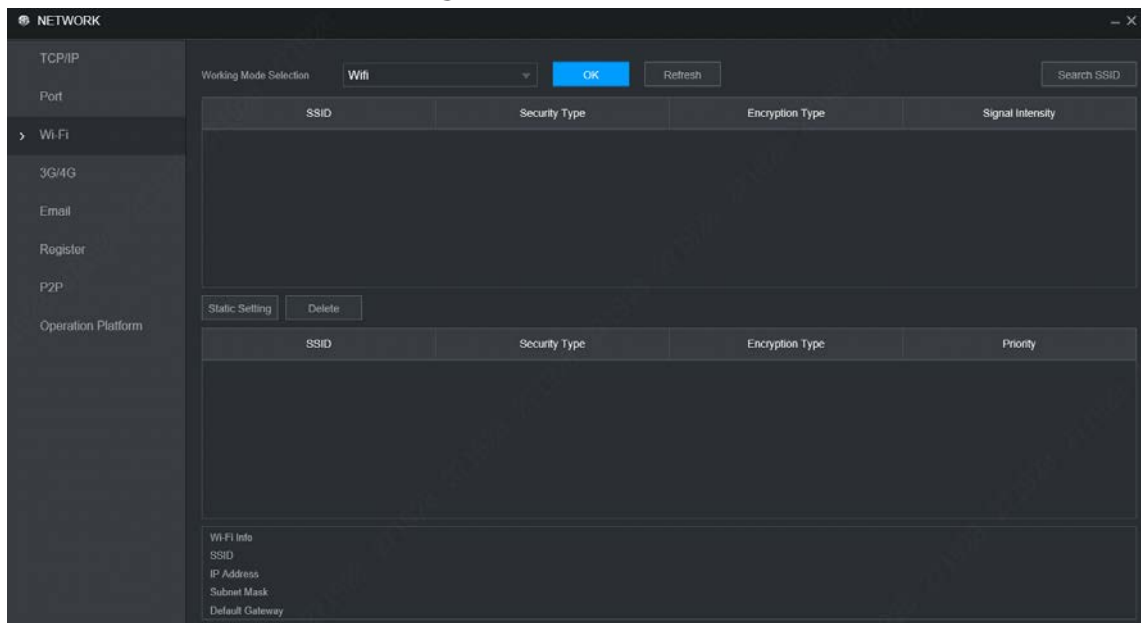

Step 3 Connect to Wi-Fi.

- Auto search
 1. Click **Search SSID**.
 2. The available Wi-Fi networks list including the information such as connection mode, authorization mode, and signal intensity.
 3. Double-click the Wi-Fi you need, enter the password and click **OK**.
- Add Wi-Fi manually
 1. Click **Static Setting**.
The **Wi-Fi** interface is displayed. See Figure 5-30.

Figure 5-30 Wi-Fi Setting

Wi-Fi

SSID

Connection Status: No Connection

Priority: 1

Verification: WPA2-PSK

Encryption Type: AES

Password

IP Address: 0 . 0 . 0 . 0 DHCP

Subnet Mask: 0 . 0 . 0 . 0

Default Gateway: 0 . 0 . 0 . 0

OK Cancel

2. Enter SSID and password, select priority level, verification type and authentication type, set IP address, subnet mask, and default gateway.

If you select **DHCP** check box, after successful connection, the system automatically obtains the IP address, subnet mask, and gateway.

3. Click **OK**.

Step 4 Click **OK**.

Click **Refresh** to refresh the connection status.

After successful connection, you can view the current hot spot, IP address, subnet mask, and gateway in **Wi-Fi Info**.

5.5.2.2 Ap

The device can work as a hotspot to share the network connection to other terminals. The terminals connected to the hot spot can log in to the device through host IP address (192.168.0.108). After login, you can view videos on the device.

Step 1 Select Setting > Network > Wi-Fi.

The **Wi-Fi** interface is displayed.

Step 2 Select **Ap** as the working mode.

The **Ap** interface is displayed. See Figure 5-31.

Figure 5-31 Ap Setting

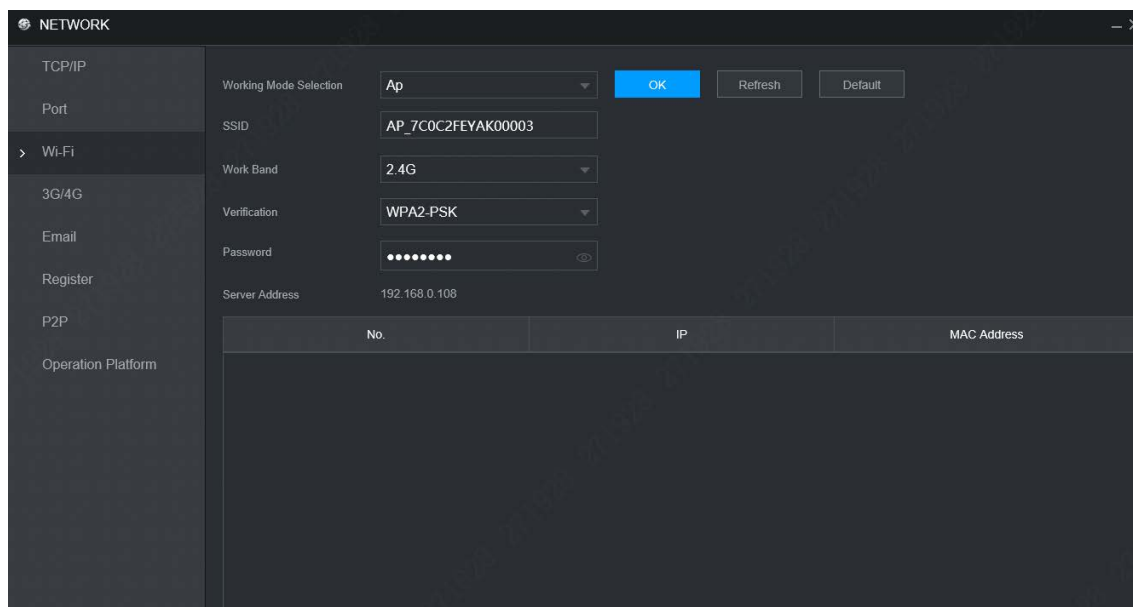

Step 3 Enter SSID information, select work band and verification type, and then enter the connection password.

- The work band can only be 2.4G.
- Select the check box behind **Password**, and the password will be visible. The default password is 12345678.

Step 4 Click **OK**.

5.5.3 3G/4G

Prerequisites

- Make sure the device is equipped with 3G/4G module and inserted with SIM card from communication operators.
- The dial number, user name, and password have been obtained from the Communication Operator.

Procedure

Step 1 Select Setting > Network > 3G/4G.

The **3G/4G** interface is displayed. See Figure 5-32.



After 3G/4G module is connected, the module information and wireless signal are displayed; if not, click **Search** to search for wireless signal.

Figure 5-32 3G/4G

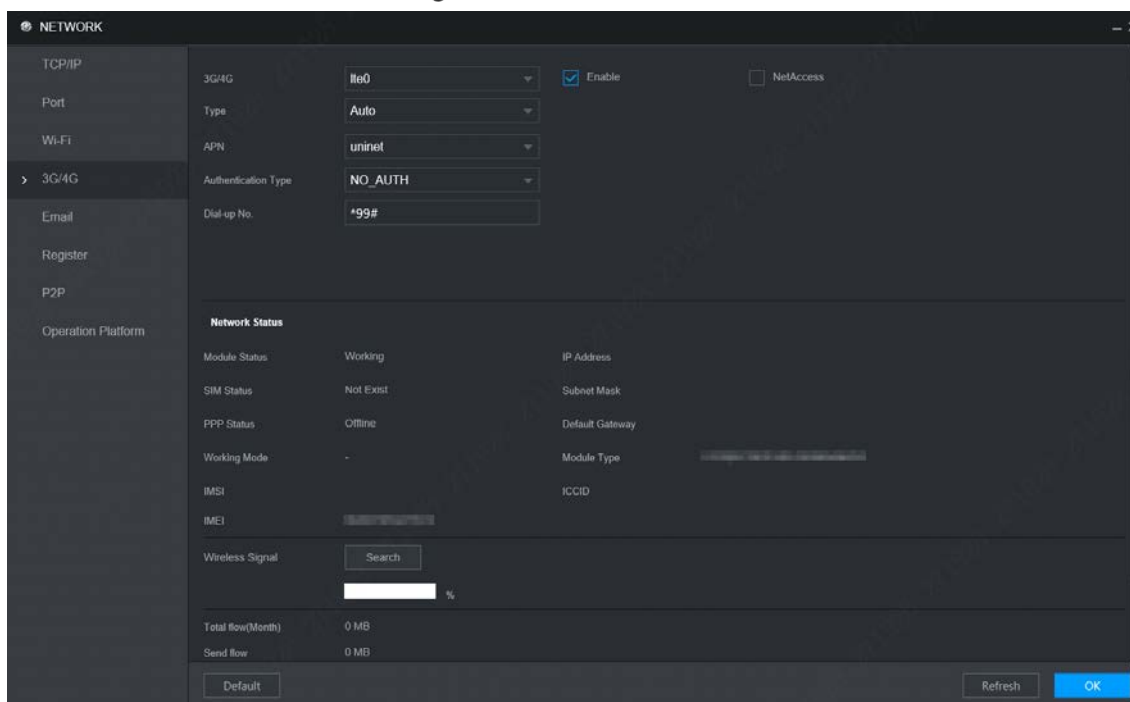

Step 2 Select **3G/4G** and **Enable** to enable the network. This function is enabled by default.

Step 3 Configure parameters. For details, see Table 5-12.

Table 5-12 3G/4G parameters description

Parameter	Description
NetAccess	When the Device is accessed to private network, select the NetAccess check box, enter APN name and select authentication mode. If PAP or CHAP is selected for authentication mode, enter user name and password, then the device is automatically accessed to private network.
Type	When enabled, the network type is displayed, which is used to distinguish between the 3G/4G modules of different communication operators, such as TD-LTE.
APN	Displays access point of Communication Operator. To manually set up APN , select Customized .
Authentication Type	Includes PAP, CHAP, and NO_AUTH protocols. The system automatically recognizes and displays the enabled protocol.
Dial-up No	Enter the dial number provided from the Communication Operator.
User Name	This parameter needs to be set up when AUTH is set to PAP or CHAP.
Password	The system automatically recognizes the user name and password.
Network Status	After successful dial-up, all relevant information is displayed without any setup needed. Such information includes module status, SIM status, PPP status, working mode, IMSI, IMEI, IP address, subnet mask, gateway, and module type.
Wireless Signal	Click Search to search for wireless signals.

Step 4 Click **OK**.

After access is succeeded, the obtained IP address is displayed.

5.5.4 Email

You can configure the email settings to enable the system to send the email as a notification when there is an alarm event occurs, such as video detection and system events.

Step 1 Select Setting > Network > Email.

The **Email** interface is displayed. See Figure 5-33.

Figure 5-33 Email

The screenshot shows the 'Email' configuration page within a 'NETWORK' settings application. On the left, a sidebar lists various network settings: TCP/IP, Port, Wi-Fi, 3G/4G, Email (selected), Register, P2P, and Operation Platform. The main area contains the following configuration options:

- Enable:** A checkbox that is currently unchecked.
- SMTP Server:** A text input field containing 'MailServer'.
- Port:** A text input field containing '25', with '(1-65535)' shown as a range.
- Anonymous:** A checkbox that is currently unchecked.
- Username:** A text input field.
- Password:** A text input field with masked characters (dots).
- Sender:** A text input field.
- Encryption Type:** A dropdown menu set to 'TLS'.
- Subject:** A text input field containing 'XVR ALERT'.
- Attachment:** A checkbox that is checked.
- Receiver:** A list of email addresses with '+' and '-' icons for adding or removing recipients.
- Sending Interval:** A text input field containing '120', with '(5)(0-3600)' shown as a range.
- Health Mail:** A checkbox that is currently unchecked.
- Sending Interval:** A text input field containing '60', with 'min. (30-1440)' shown as a range.



At the bottom of the interface, there are three buttons: 'Test' (green), 'Refresh' (grey), and 'OK' (blue).

Step 2 Select **Enable** to enable email function.

Step 3 Configure parameters. For details, see Table 5-13.



Table 5-13 Email parameters description

Parameter	Description
SMTP Server	Configure the address of Simple Mail Transfer Protocol. For details, see Table 5-14.
Port	Enter the port value of SMTP server. For details, see Table 5-14.
Anonymous	If Anonymous is selected, the sender information is not displayed when sending an email.
User Name	Enter the user name and password of SMTP server. For details, see Table 5-14.
Password	
Sender	Sender Email Address
Encryption Type	In the Encrypt list, select an encryption type from NONE, SSL, and TLS. For details, see Table 5-14.
Subject	You can enter no more than 63 characters in Chinese, English, and Arabic numerals.
Attachment	If Attachment is enabled, when an alarm takes place, the system can send alarm linked snapshots.

Parameter	Description
Receiver	Receiver's Email address You can enter up to three email addresses separated by colons.
Sending Interval	<p>This is the interval that the system sends an email for the same type of alarm event, which means, the system does not send an email upon any alarm event.</p> <p>The interval ranges from 0 through 3600 seconds. 0 means that there is no interval.</p>  <p>This setting helps to avoid the large amount of emails caused by frequent alarm events.</p>
Health Mail	<p>The system can send a test email to check the connection.</p> <p>Select the Health Mail check box, and then enter the interval. The system can send a test email to check the connection after the specified interval.</p>  <p>The value ranges from 30 minutes to 1440 minutes.</p>
Test	Click Test to test if emails can be sent out and received as intended. If the configuration is correct, the receiver's email account will receive the test email. Before testing email, click OK to save the email configuration.

For the configuration of major mailboxes, see Table 5-14.

Table 5-14 Common mailbox configuration parameters

Mailbox type	SMTP server	Authentication method	Port	Description
QQ	smtp.qq.com	SSL	465	<ul style="list-style-type: none"> Do not select None for encryption. The mailbox must have applied SMTP service. The password must be an "authorized password". Both the QQ login password and email login password are invalid.  <p>Obtain the authorized password when your mailbox is applying for SMTP service.</p>
		TLS	587	
163	smtp.163.com	SSL	465/994	<ul style="list-style-type: none"> The mailbox must have applied "SMTP" service. The password must be an "authorized password". The email login password is invalid.  <p>Obtain the authorized password when your mailbox is applying for SMTP service.</p>
		TLS	25	
		NONE	25	
Sina	smtp.sina.com	SSL	465	

Mailbox type	SMTP server	Authentication method	Port	Description
		NONE	25	The mailbox must have applied "SMTP" service.
126	smtp.126.com	NONE	25	The mailbox must have applied "SMTP" service.

Step 4 Click **OK**.

5.5.5 Register

After successfully auto registered, when the device is connected into the Internet, it will report the current location to the specified server to make it easier for the client software to access to the device, and to view and monitor it.

Step 1 Select Setting > Network > Register.

The **Register** interface is displayed. See Figure 5-34.

Figure 5-34 Register

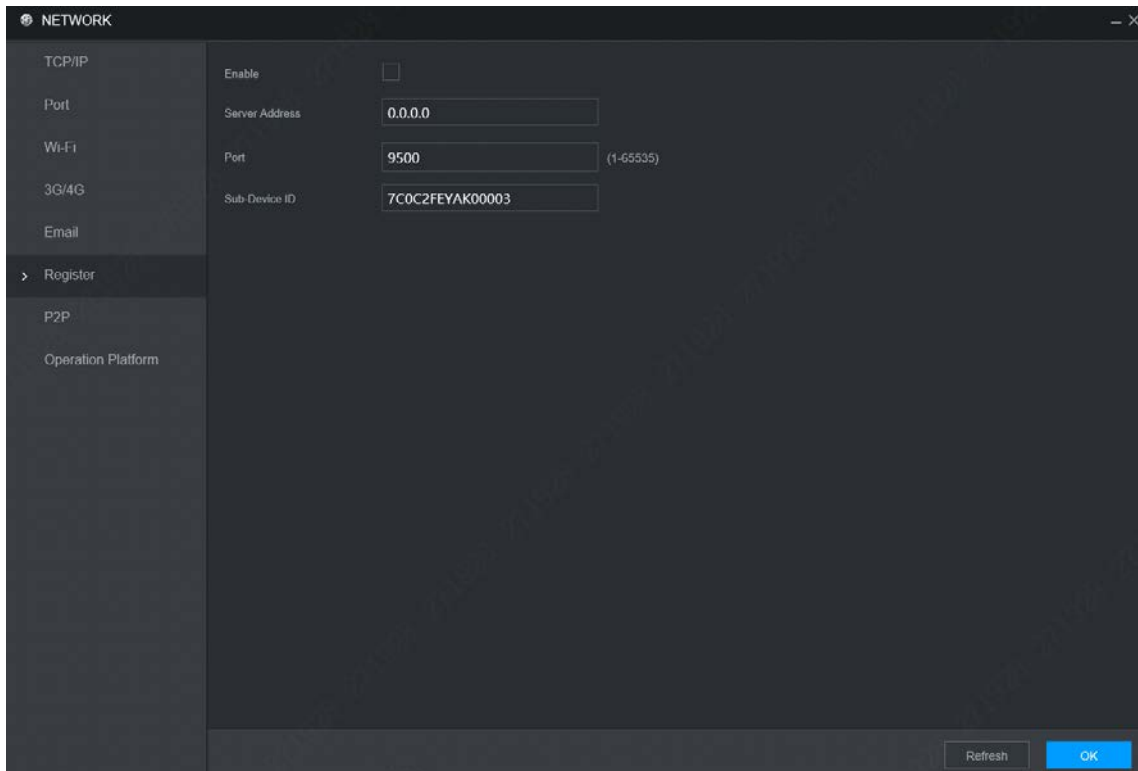

Step 2 Select the **Enable** check box. (Selected by default)

Step 3 Configure parameters. For details, see Table 5-15.

Table 5-15 Register parameters

Parameter	Description
IP Address	Enter the IP address or domain name of the server to register.
Port	Enter the port of the server for register.
Sub-device ID	Unique ID for identifying the device. When different devices register to the same server, the sub-device IDs should be different.

Step 4 Click **OK**.

5.5.6 P2P

P2P is a private network penetration technology. With this technology, you do not need to apply for dynamic domain name, set port mapping, or deploy transit server. You can add devices for management by either of the following two ways.

- Scan the QR code on the interface to download APP, and register an account.
- Log in www.gotop2p.com platform to register, and then add devices by device serial number.



Before using P2P, make sure that the device is connected to the Internet.

Preconditions

- The device had been connected to the Internet.
- App has been downloaded and installed on your mobile phone.

Procedure

Step 1 Select Setting > Network > P2P.

The **P2P** interface is displayed, see Figure 5-35.

Figure 5-35 P2P

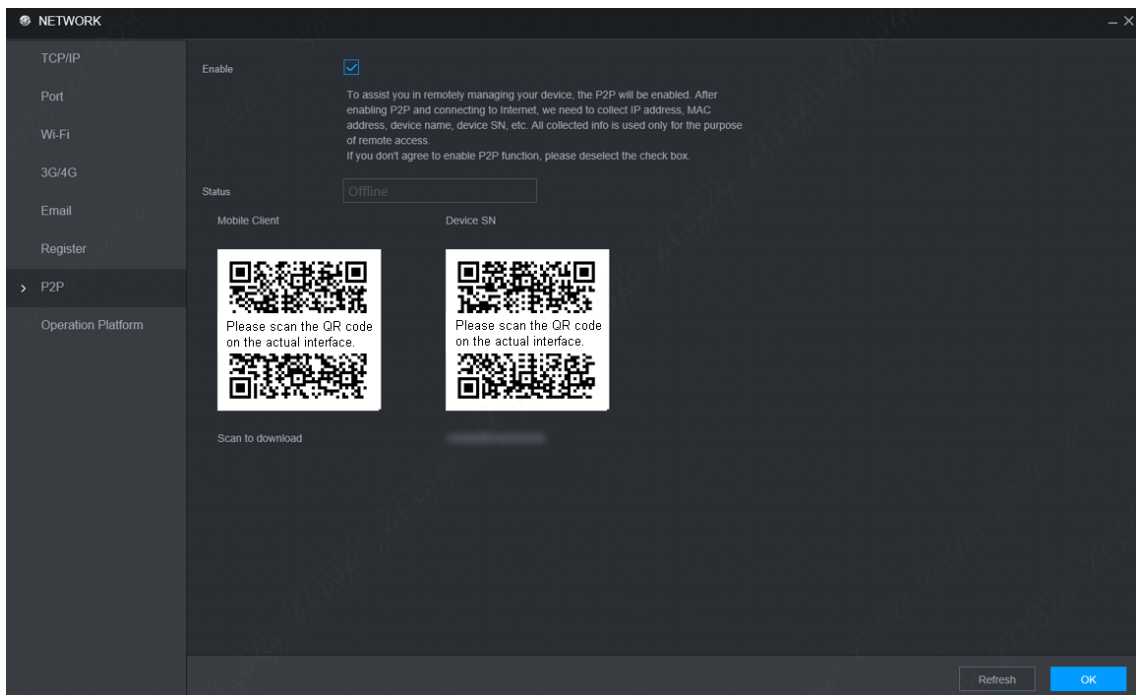

Step 2 Select **Enable** to enable P2P.

Step 3 Click **OK**.

The p2p registration is successful when the **Status** shows **Online**.

Step 4 Use Mobile Client to scan the QR code under device SN to add the device to Mobile Client.



Please scan the QR code on the actual interface of device.

5.6 Managing Storage Device

You can configure storage, basic information, manage HDD, and review HDD information.

5.6.1 Basic

On the Local interface, you can set up the strategy when the Disk is full and recordings mode.

Step 1 In the main menu, select **Setting>Storage > Basic**.

The **Basic** interface is displayed. See Figure 5-36.

Figure 5-36 Basic

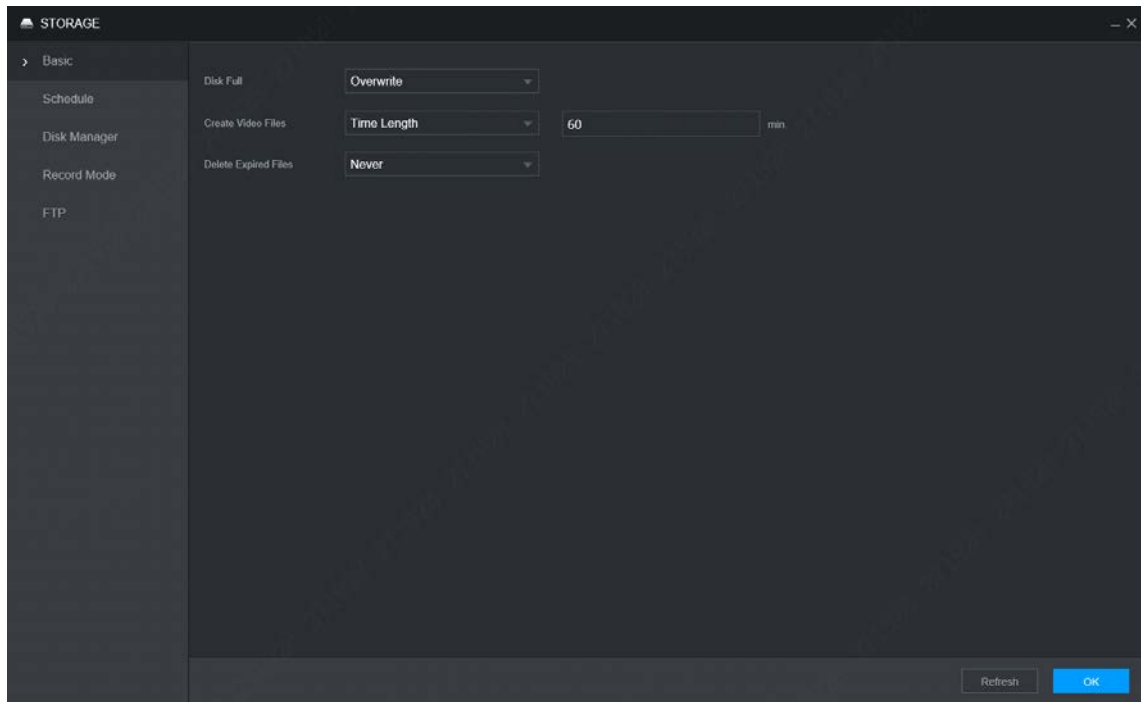

Step 2 Configure basic information

- Select the processing strategy of stopping recording and overwriting earlier recordings when TF Card is full.
 - ◇ **Stop:** The system stops recording when the disk is full.
 - ◇ **Overwrite:** The system overwrites the oldest files and keeps recording when the disk is full.
- Set up the time length or file size for Video Packaging.

Select the required packaging manner from the **Create Video Files** drop-down list. Including **Time Length** and **File Size**.

 - ◇ Set the length of time for each video file. The default value is 60 minutes, and the range is 1 minute –120 minutes.
 - ◇ Set the size of file for each video file. The default value is 1024M, and the range is 128M–2048M.
- Set the strategy of deleting old files automatically.

You can enable this function to delete recorded videos or images saved in TF card or FTP server regularly according to the time gap you have set.



After setting file auto deletion, deleted files cannot be recovered.

Step 3 Click **OK**.

5.6.2 Disk Manager

Set the read and write properties of the TF card and view the capacity information of the HDD.

Step 1 Select Setting > Storage > Disk Manager.

The **Disk Manager** interface is displayed. See Figure 5-37.

Step 2 Set the read and write properties of the TF card. You can set the TF card as the Read/Write disk, Read-Only disk or Redundancy disk under the **Properties** column.

- Read/Write: You can read data from TF card and save data in TF card.
- Read-Only: You can only read data from TF card if set to read-only disk.
- Redundancy: If the device is connected to two or more TF cards, one of the TF cards can be set as the redundancy one for recording backup.



Select TF card and click **Format** to clear all data in the SD card. Proceed with caution.

Figure 5-37 Disk Manager

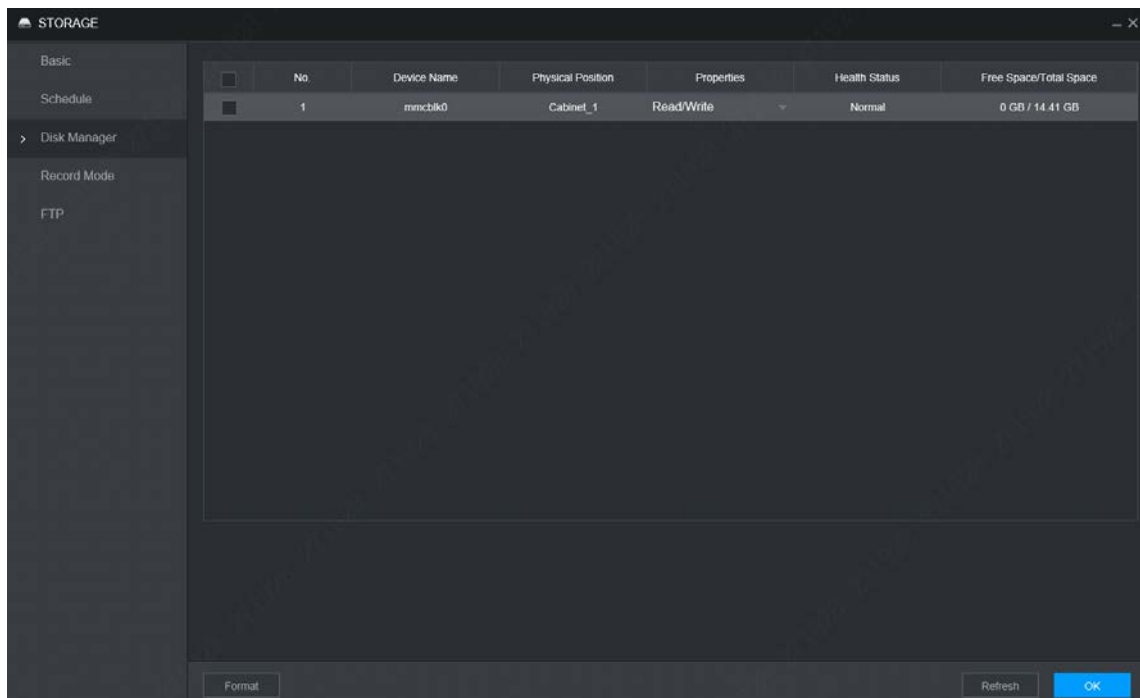

Step 3 Click **OK**.

5.6.3 FTP

Configure FTP server, and then you can save videos and snapshots to the FTP server.

Prerequisites

You have deployed a FTP server, and created a user with the read & write permission.



The created FTP user should have write permission; otherwise the upload of videos, audios, and snapshots will be failed.

Procedure

Step 1 Select Setting > Storage > FTP.

The **FTP** interface is displayed, see Figure 5-38.

Figure 5-38 FTP

Step 2 Select **Enable** to enable FTP upload and select FTP type.



- Select FTP or SFPT from the drop-down list. SFTP is recommended to enhance network security.
- When **FTP** is selected, the system gives a risk prompt. Select **OK** or **Cancel** as needed.

Step 3 Configure parameters. For details, see Table 5-16.

Table 5-16 FTP parameters description

Parameter	Description
Server Address	The IP address of the host PC that is installed with the FTP/SFTP server.
Port	By default, SFTP port is 22 and FTP port is 21.
User Name	The user name and password used to access the server.
Password	
Anonymous	Select Anonymous if you want to log in to the server anonymously.
Storage Path	<p>Create folder on FTP server.</p> <ul style="list-style-type: none"> • If you do not enter the name of remote directory, the system automatically creates the folders according to the IP, time, and channel. • If you enter a name for the remote directory, the system creates a folder with the entered name under the FTP/SFTP root directory first, and then automatically creates folders based on IP, time, and channel.

Parameter	Description
File Size	<p>Enter the size of the uploaded recorded video.</p> <ul style="list-style-type: none"> ● If the entered size is less than the recorded video size, only a section of the recorded video can be uploaded. ● If the entered size is more than the recorded video size, the whole recorded video can be uploaded. ● If the entered size is 0, the whole recorded video will be uploaded.
Choose channel	Select the channel that you want to apply the FTP settings.
Weekday	Select the week day and set the time period that you want to upload the recorded files. You can set two periods for each week.
Period	Select the record type (Alarm, MD, and General) that you want to upload. After selecting the corresponding recording type next to the corresponding period, the selected recording type will be uploaded during the configured period.
Picture Upload Interval	<ul style="list-style-type: none"> ● When the Snapshot Type is Schedule, the upload method should be determined based on the image upload interval and snapshot interval. <ul style="list-style-type: none"> ◇ If this interval is longer than snapshot interval, the system uploads the most recent snapshot. For example, if the interval is 5 seconds and snapshot interval is 2 seconds, the system sends an upload command to upload the next snapshot every 5 seconds. ◇ If this interval is shorter than snapshot interval, the system uploads the snapshot per the snapshot interval. For example, if the interval is 5 seconds and snapshot interval is 10 seconds, the system uploads the snapshot every 10 seconds. ● When the Snapshot Type is Event, the system uploads the snapshot as per the snapshot interval.  <p>You can change the Interval and Type. For details, see "5.4.2.2 Snapshot".</p>

Step 4 Click **Test** to test if the FTP/SFTP server is successfully configured.

- The system pops up a message to indicate success or failure.
- If failed, please check the network connection or configurations.

Step 5 Click **OK**.

5.7 Configuring System

You can configure system information, including serial port parameters, security management, and vehicle information.

5.7.1 Configuring Serial Port Parameters

You can configure the serial port parameters such as baud rate, data bit, stop bit, and parity.

Step 1 Select Setting > System > Serial Port.

The **Serial Port** interface is displayed. See Figure 5-39.

Figure 5-39 Serial port

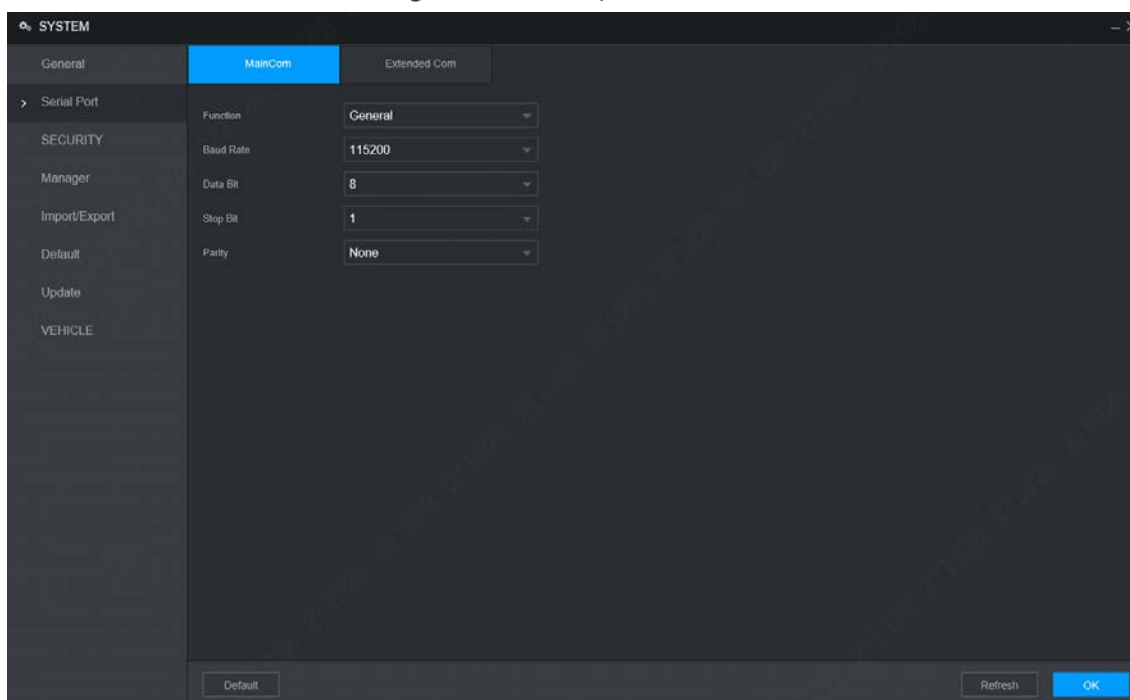

Step 2 Configure parameters. For details, see Table 5-17.

Table 5-17 Serial port parameters description

Parameter	Description
Function	Select the corresponding protocol. <ul style="list-style-type: none"> Console: Upgrades programs and debug by using the serial interface and mini terminal software. GPS: Used to transmit real-time GPS data.
Baud rate	The times of signal changes on the transmission line in time unit. <ul style="list-style-type: none"> The default baud rate is 115200 for a console. The default baud rate is 9600 for a transparent serial port.
Data Bit	Select a data bit. The options include 5, 6, 7, and 8 .
Stop Bit	Select a stop bit. The options includes 1, 1.5, and 2 .
Test	Select a parity mode from None, Odd, Even, Mark, and Null. The default is None .

Step 3 Click **OK**.

5.7.2 Managing Security

It is to set security strategy to guarantee device network and data safety. It includes setting host IP access right and enabling system service, etc.

5.7.2.1 System Service

The corresponding service can only be used after the system service is turned on.

Step 1 Select Setting > System > Security > System Service.

The **System Service** interface is displayed. See Figure 5-40.

Figure 5-40 System service

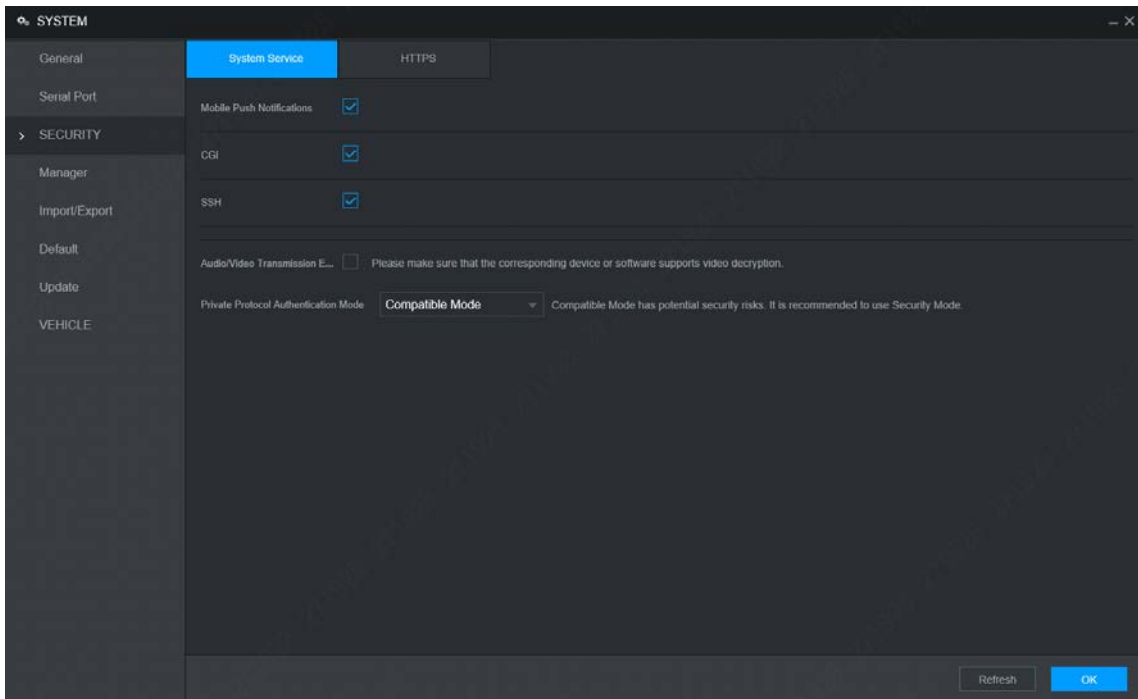

Step 2 Select whether to enable mobile phone push, CGI, SSH, or audio/video transmission encryption as needed.

- App can receive alarm push only when the mobile phone push is enabled and the app has subscribed alarm.
- After enabling CGI, a third-party platform can connect to this device via the CGI protocol.
- When audio/video transmission encryption is enabled, audio/video transmission will be encrypted. Related devices or software shall support video decryption.

Step 3 Click **OK**.

5.7.3 Configuring Vehicle Info

You can set the vehicle speed and position report.

5.7.3.1 Configuring Speed

Step 1 Select Setting > System > Vehicle > Speed.

The **Speed** interface is displayed. See Figure 5-41.

Figure 5-41 Speed

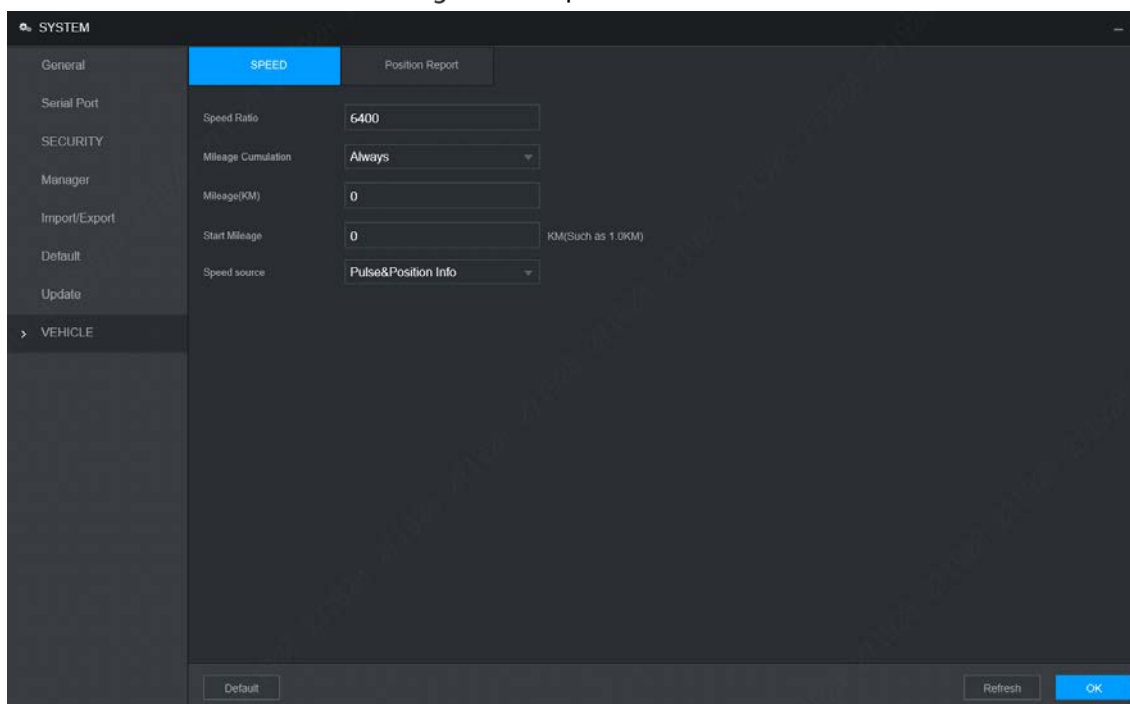

Step 2 Configure parameters. For details, see Table 5-18.

Table 5-18 Speed parameters description

Parameter	Description
Speed Ratio	The parameter for converting speed.
Mileage Cumulation	Select the vehicle mileage cumulation mode.
Mileage	Displays the total mileage.
Start Mileage	Enter the initial mileage of the vehicle.
Speed source	Select where the speed is obtained, including Pulse , Position Info , and Pulse&Position Info . <ul style="list-style-type: none"> ● Pulse 1: Get the speed information from vehicle pulse system. ● Position Info: Get the speed information from positioning system. ● Pulse&Position Info: Gets the speed information from both the pulse system and positioning system. Information from the pulse system is used first.

Step 3 Click **OK**.

5.7.3.2 Configuring Position Report

You can configure the position report strategy to be device auto report or report per platform schedule.

Step 1 Select Setting > System> Vehicle> Position Report.

The **Position Report** interface is displayed.

Step 2 Configure the report strategy.

- Device auto report.
 1. In the **Report Strategy** list, select Device Auto.
The **Device Auto** setting interface is displayed. See Figure 5-42.

Figure 5-42 Position report (device auto)

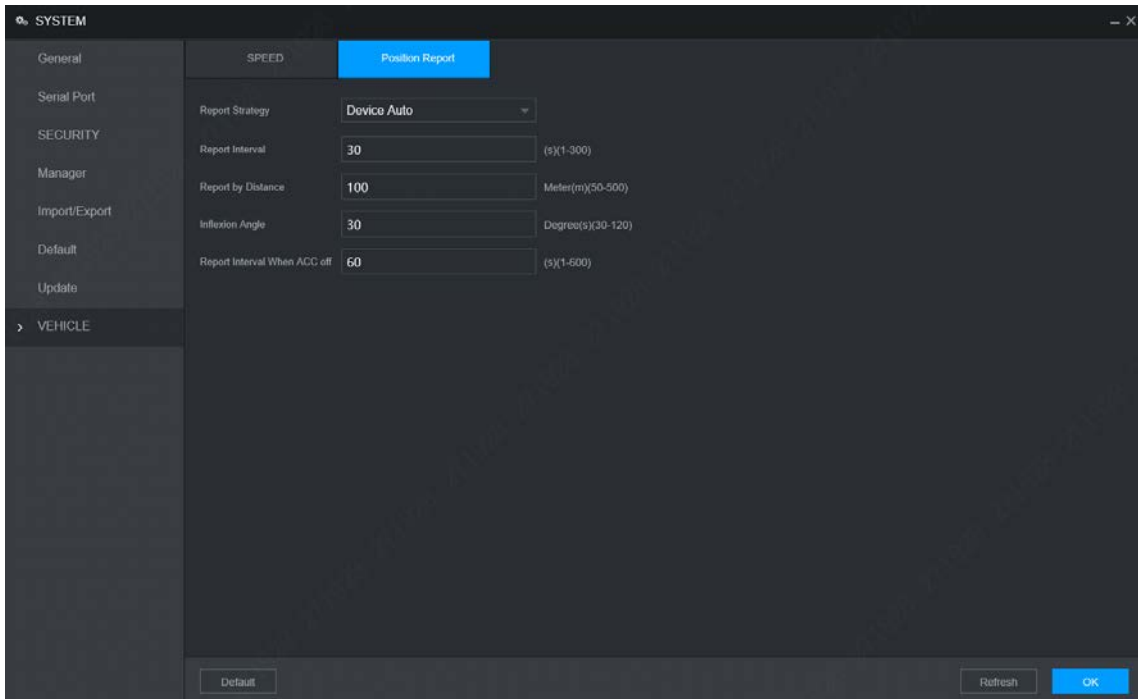

2. Configure parameters. For details, see Table 5-19.

Table 5-19 Device auto report parameters description

Parameter	Description
Report Interval	When the vehicle ACC status is on, the system report the position to platform according to the configured report interval, report distance, and inflexion angle. The system reports vehicle position to platform only if one of conditions is satisfied.
Report by Distance	
Inflexion Angle	
Report Interval When ACC off	When the vehicle ACC status is off, the system report the position to platform according to the configured report interval.

- Platform schedule.

In the **Report Strategy** list, select **Platform Schedule**. The **Platform Schedule** setting interface is displayed. See Figure 5-43.

The platform obtains the device position by the configured schedule. The schedule is configured at the platform. See the user's manual for the platform.

Figure 5-43 Position report (platform schedule)

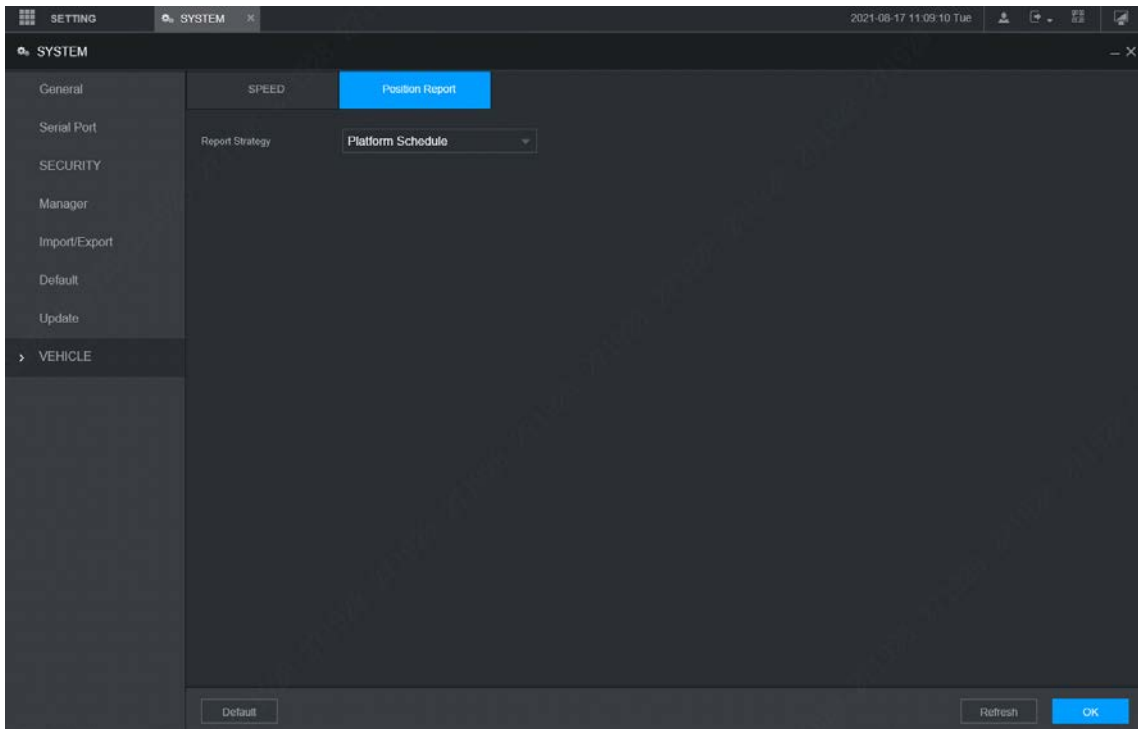

Step 3 Click **OK**.

5.8 Managing User Account

You can add, modify and delete user accounts and groups, and configure security questions for admin account.

The Default User and Authority

The default user account is admin.

- The admin account is defined as the highly privileged user by default.
- To manage user accounts easily, when defining the user account authority, it is recommended to give lower authority to common user accounts than advanced user account.

About User and User Group

You can manage the account by user and user group, and the name cannot be repeated.

- You can set maximum 64 users and 20 groups.
- The default group name by "User" and "Admin" cannot be deleted.
- Select the authorities to the user of a group. However, the authorities of the admin account cannot be specified at your will.
- Every user must belong to only one group. When selecting a group for a user, permissions of the user can only be a subset of group permissions and cannot exceed permission attributes of the group.
- Both the user name and group name support 1–3 characters and can only consist of letter, number, underline (_), and hyphen (-).

5.8.1 Managing User

You can add, delete, or modify user, and set the authorities for the user of a group.

Adding a user

Step 1 Select Setting > Account > Account > User.

The **User** interface is displayed. See Figure 5-44.

Figure 5-44 User

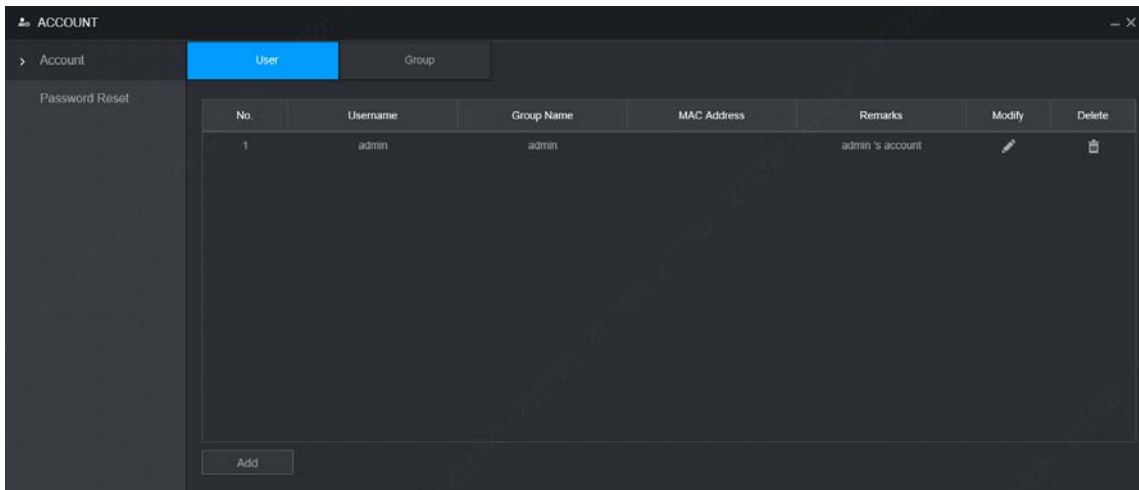

Step 2 Click **Add**.

The **Add** interface is displayed. See Figure 5-45.

Figure 5-45 Add

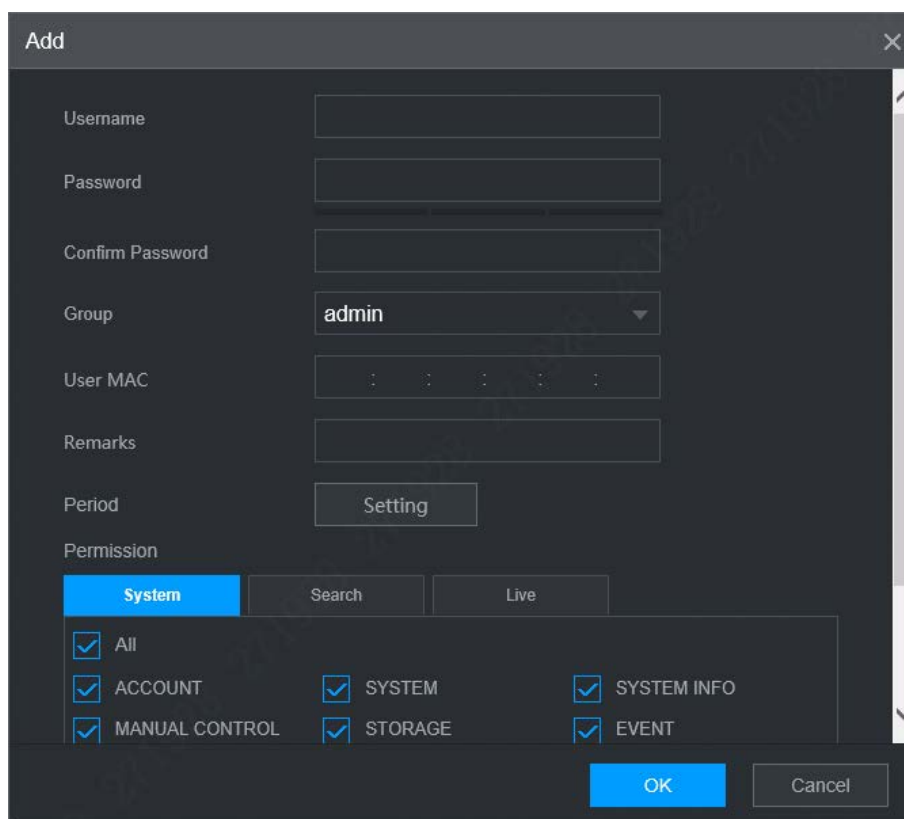

The screenshot shows a form titled 'Add' with the following fields and options:

- Username: Text input field
- Password: Text input field
- Confirm Password: Text input field
- Group: Dropdown menu with 'admin' selected
- User MAC: Text input field with a colon separator
- Remarks: Text input field
- Period: Button labeled 'Setting'
- Permission: Section with three tabs: 'System' (active), 'Search', and 'Live'. Below the tabs are three columns of checkboxes:
 - Column 1: All, ACCOUNT, MANUAL CONTROL
 - Column 2: SYSTEM, STORAGE
 - Column 3: SYSTEM INFO, EVENT

At the bottom right, there are 'OK' and 'Cancel' buttons.

Step 3 Configure parameters. For details, see Table 5-20.

Table 5-20 Parameters description for adding user

Parameter	Description
User Name	Enter the user name and password, and conform the password.
Login PWD	
Confirm Password	
Group Name	Select the group that the users belong to.
User MAC	Enter user MAC address that is allowed to login the device.
Remark	Enter a description of the user.
Period	Click Setting to set a valid period. The user is only allowed to log in to the device in the set period.

Step 4 Click **System**, **Search**, or **Live** to set up user permissions.



- Select **All** to select all authorities in the category.
- The authorities of the admin account cannot be changed.

Step 5 Click **OK**.



Click to modify user information; click to delete the user.

Changing Password

Step 1 On the **User** interface, click .

The **Modify** interface is displayed. See Figure 5-46.

Figure 5-46 Modify

Step 2 Select the **Modify Password** check box, and then enter old password, new password, and confirm password in the corresponding box.

Step 3 Select the authority, including system, playback, and real-time monitoring authorities.

Step 4 Click **OK**.



- The new password can be set from 8 characters through 32 characters and contains at least two types from number, letter and special characters (excluding ' ' \ ; : &). Please enter a strong password according to the password strength indication.
- A user authorized to manage user accounts can modify its own password and the passwords of other users.

5.8.2 Managing Group

You can perform the operations to manage the group account, such as adding a group, deleting a group, and modifying a group.

Step 1 Select Setting > Account > Account > Group.

The **Group** interface is displayed, see Figure 5-47.

Figure 5-47 Group

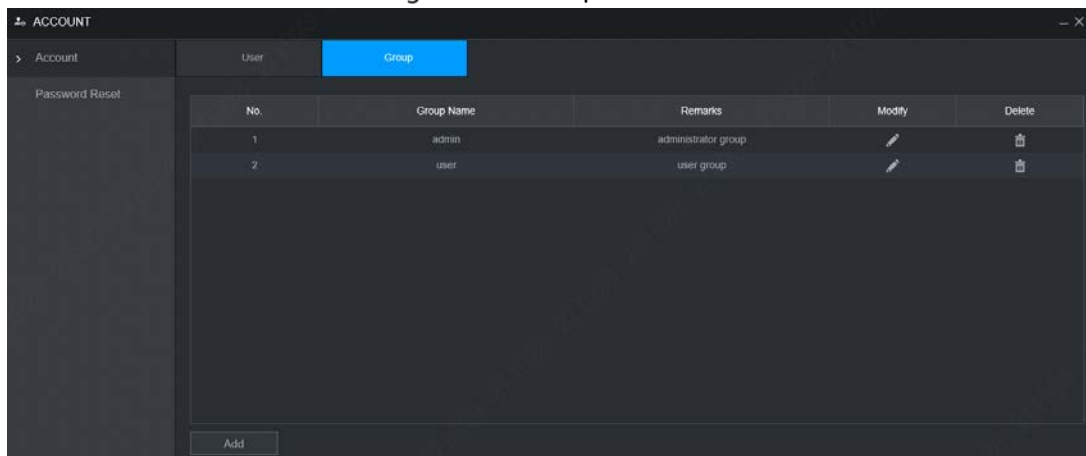

Step 2 Click **Add**.

The **Add** interface is displayed. See Figure 5-48.

Figure 5-48 Add

Group Name:

Remarks:

Permission

System | Search | Live

<input type="checkbox"/> All	<input type="checkbox"/> SYSTEM	<input type="checkbox"/> SYSTEM INFO
<input type="checkbox"/> ACCOUNT	<input type="checkbox"/> STORAGE	<input type="checkbox"/> EVENT
<input type="checkbox"/> MANUAL CONTROL	<input type="checkbox"/> CAMERA	<input type="checkbox"/> SECURITY
<input type="checkbox"/> NETWORK	<input type="checkbox"/> MAINTENANCE	
<input type="checkbox"/> BACKUP		

OK Cancel

Step 3 Set group name and memo.

A group name consists of letters, numbers, and special characters (including "_", "@", ":").

Step 4 Select the authority, including system, playback, and real-time monitoring authorities.



Select **All** to select all authorities in the category.

Step 5 Click **OK**.



Click  to modify the corresponding group information; click  to delete the group.

5.8.3 Resetting Password

You can reset the password through the reserved phone number when you forget the login password of admin.

Step 1 Open a browser and login the WEB interface of device.

The **Login** interface is displayed. See Figure 5-49.

Figure 5-49 Login

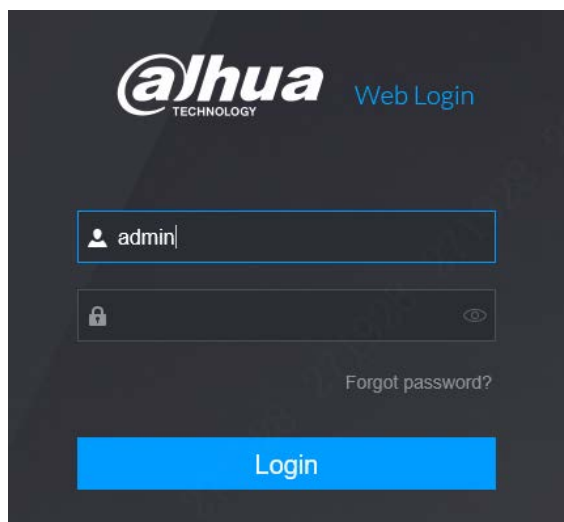

Step 2 Click **Forgot Password?**

The **Password Reset** interface is displayed. See Figure 5-50

Figure 5-50 Reset password (1)

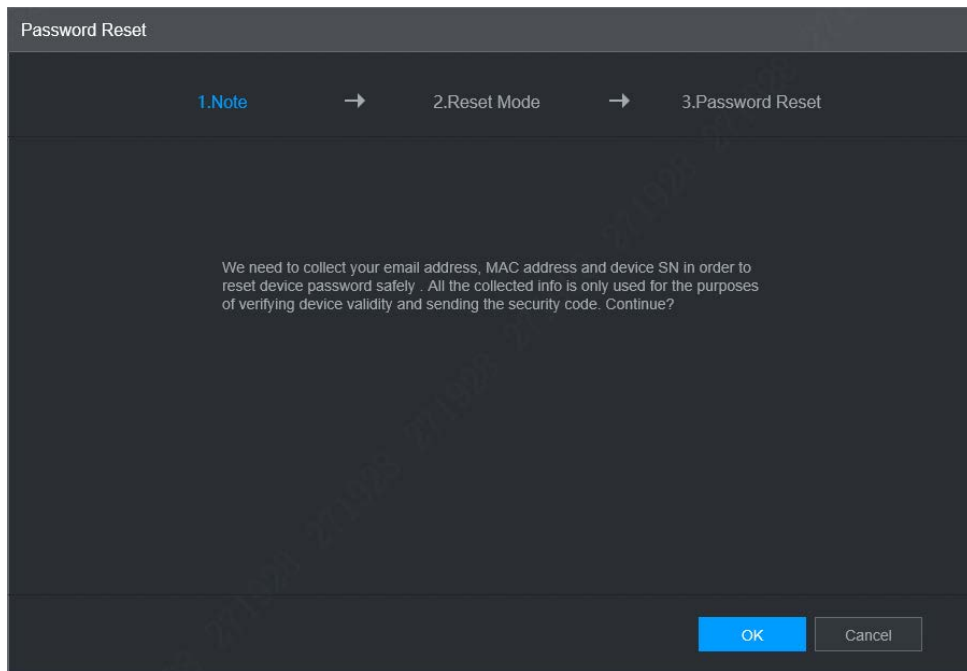

Step 3 Click **OK**.

The **Password Reset** interface is displayed. See Figure 5-51.

Figure 5-51 Reset password (2)

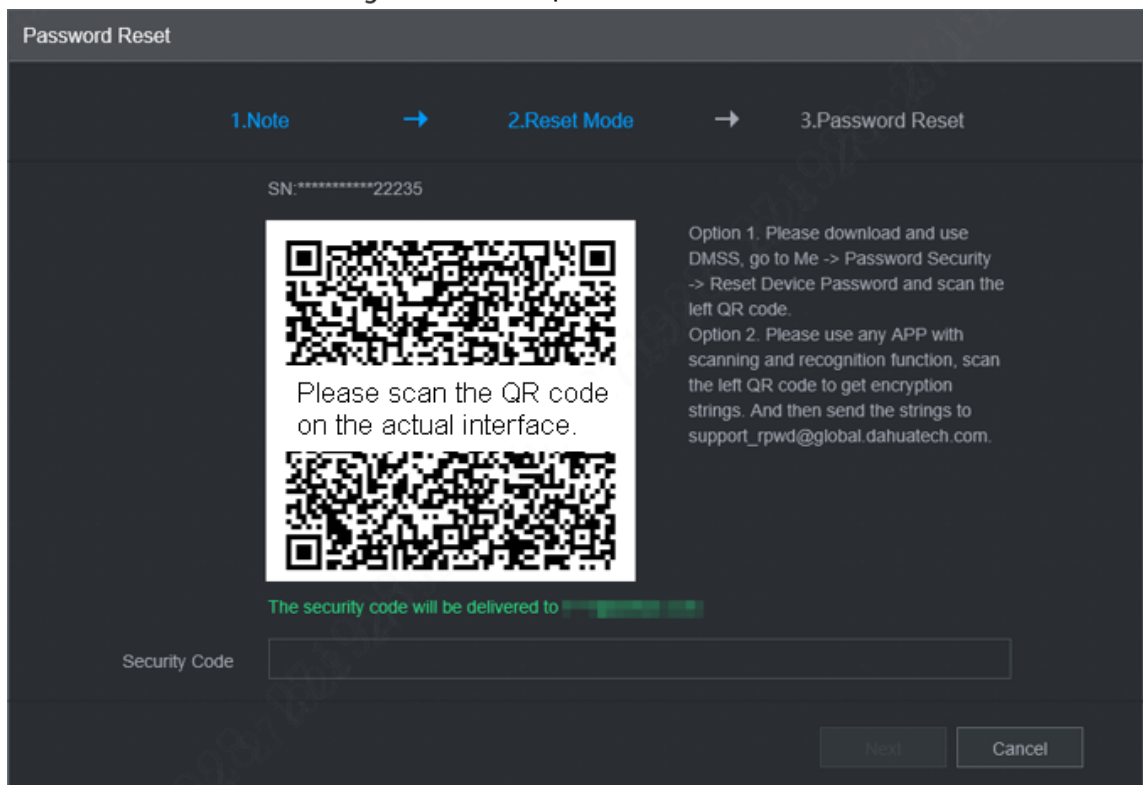

Step 4 Follow the instructions to scan the QR code and get the security code.



- Please scan the QR code on the actual interface of device.
- At most two security codes will be generated by scanning the same QR code. To get more security code, refresh the QR code.

- Please use the security code within 24 hours after you receive it. Otherwise, it will become invalid.
- Wrong security code entered for up to five times will cause account locked for 5 min.

Step 5 In the **Security Code** box, enter the security code received in your provided mailbox.

Step 6 Click **Next**.

The new password setting interface is displayed. See Figure 5-52.

Figure 5-52 New password setting

1.Note → 2.Reset Mode → 3.Password Reset

Username admin

Password

Confirm Password

Password must be 8 to 32 characters, including at least two of the following categories: numbers, uppercase letters, lowercase letters and special characters (Characters like ' ' ; : & cannot be included in).

OK

Step 7 Reset and confirm the password.

The new password can be set from 8 through 32 non-empty characters and contains at least two types from number, letter and special characters (excluding """, """, ":", ":" and "&"). Please enter a strong password according to the password strength indication.

Step 8 Click **OK**.

The system prompts successful operation and restarts. You can use the new password to log in to the device.

6 Update

6.1 System Version

You can view the device hardware characteristics, version such information.

Select **Setting > System Info > Version**.

The **Version** interface is displayed. See Figure 6-1.

Figure 6-1 Version



6.2 Update

Import the update file in the format of .bin to update the system.



- Do not disconnect the power or network, or restart or shut down the device during update cannot be used.
- Incorrect update programs may result in the device unable to work.

Step 1 Select Setting > System > Update.

The **Update** interface is displayed. See Figure 6-2.

Figure 6-2 Update

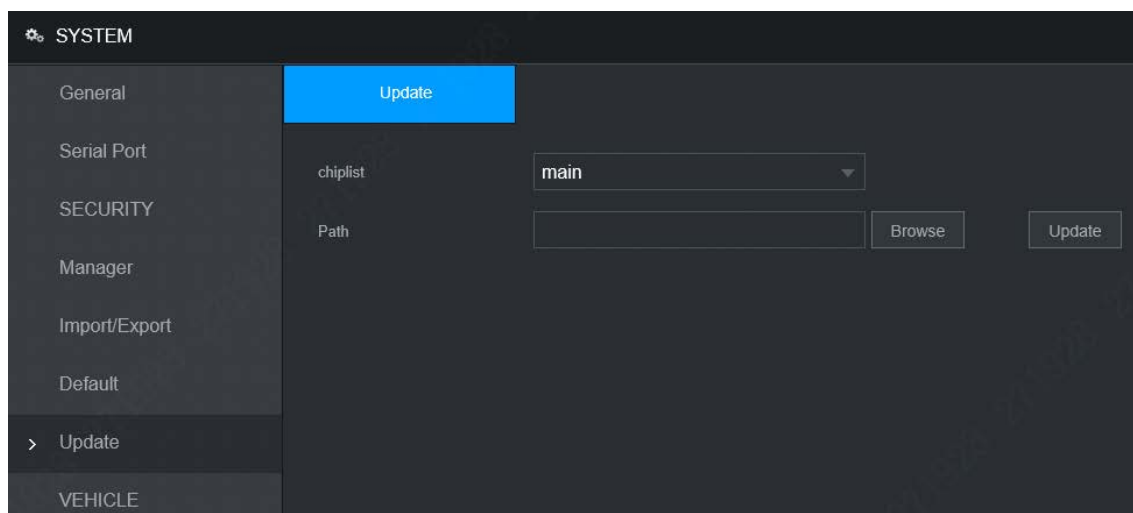

Step 2 Select the chip list that suits your actual needs.

- To upgrade system programs, select **Main** for the chip list.
- To upgrade the MCU firmware programs, select **MCU** for the chip list.

Step 3 Click **Browse** and select the upgrade files you want to use.

Step 4 Click **Update**.

The system starts upgrading. You should log in to the WEB interface again after upgrading.

7 System Maintenance

7.1 Requirement for Maintenance

To keep the device running normally, it is recommended to manage, backup, and maintain the device.

- Check the monitoring screen of device regularly.
- Delete the unused user and group regularly.
- Modify the user password every three months.
- View the system logs regularly and analyze the data to handle the abnormalities timely.
- Back up the system configurations regularly.
- Reboot this device regularly.
- Upgrade firmware regularly.

7.2 System Information

You can view device version information, logs, network information, HDD information, channel information, satellite information, and MAC information.



For version information, see “6.1 System Version.”

7.2.1 Log

You can search, view, and back up the logs to local PC.

Step 1 Select Setting > System Info > Log.

The **Log** interface is displayed. See Figure 7-1.

Figure 7-1 Log

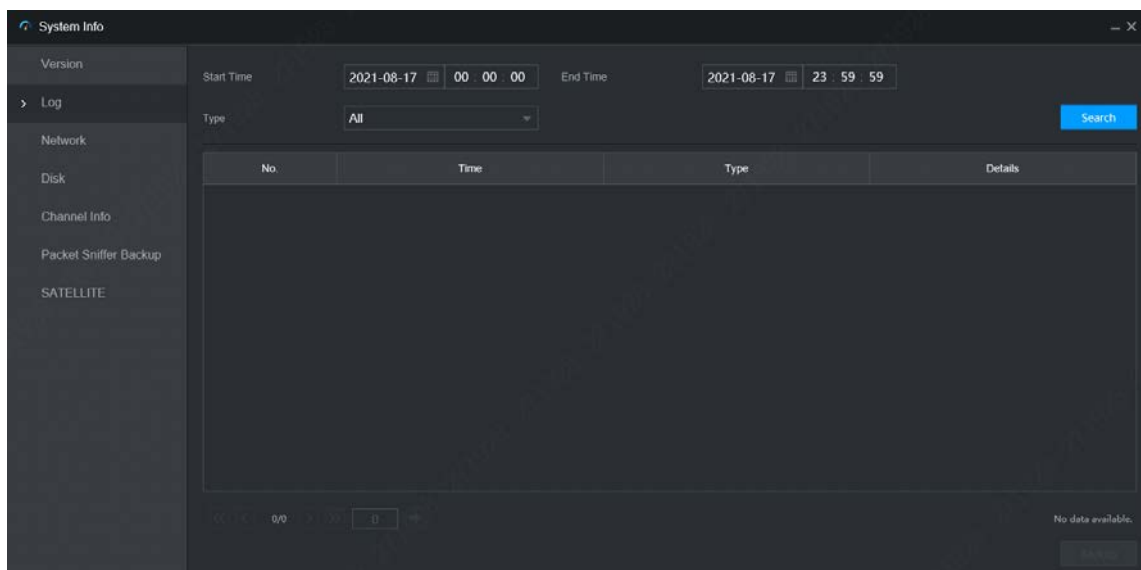

Step 2 Set up Start Time, End Time, and Type.

Step 3 Click **Search**.

The searched logs are displayed.



Select the log that you want to back up, and then click **Backup**. In the **Save as** dialog box, select the save path to save the log to PC.

7.2.2 Network Info

You can view IP information of the logged in device.

Step 1 Select **Setting > System Info > Network**. The **Network** interface is displayed. See Figure 7-2.

Step 2 Click **Refresh** and the latest network information is displayed.

Figure 7-2 Network

No.	Username	Group Name	IP Address	User Login Time
1	admin	admin	192.168.1.100	2021-08-17 13:35:44
2	admin	admin	192.168.1.100	2021-08-17 13:35:45

7.2.3 Disk

You can view the HDD information of the device, including TF Card name, location, and health.

- Select **Setting > System Info > Disk**. The **Disk** interface is displayed. See Figure 7-3.

Figure 7-3 Disk

No.	Device Name	Physical Position	Health Status	Free Space/Total Space	S.M.A.R.T
1*	mmcblk0	Cabinet_1	Normal	0 GB / 14.41 GB	

7.2.4 Channel Info

You can view the channel information.

Select **Setting > System Info > Channel Info**. The **Channel Info** interface is displayed. See Figure 7-4.

7.3 Automatic Maintenance

You can configure the automatic maintenance settings such as auto reboot, auto deleting old files, auto booting up, auto shutdown, and delay for auto shutdown.

7.3.1 Auto Reboot

Once the device is running for a long time, you can set to automatically reboot the device at idle time. After configuring auto reboot, when the device is working, it reboots according to the schedule.

Step 1 Select Setting > System > Manager.

The **Manager** interface is displayed, see Figure 7-6.

Figure 7-6 Manager

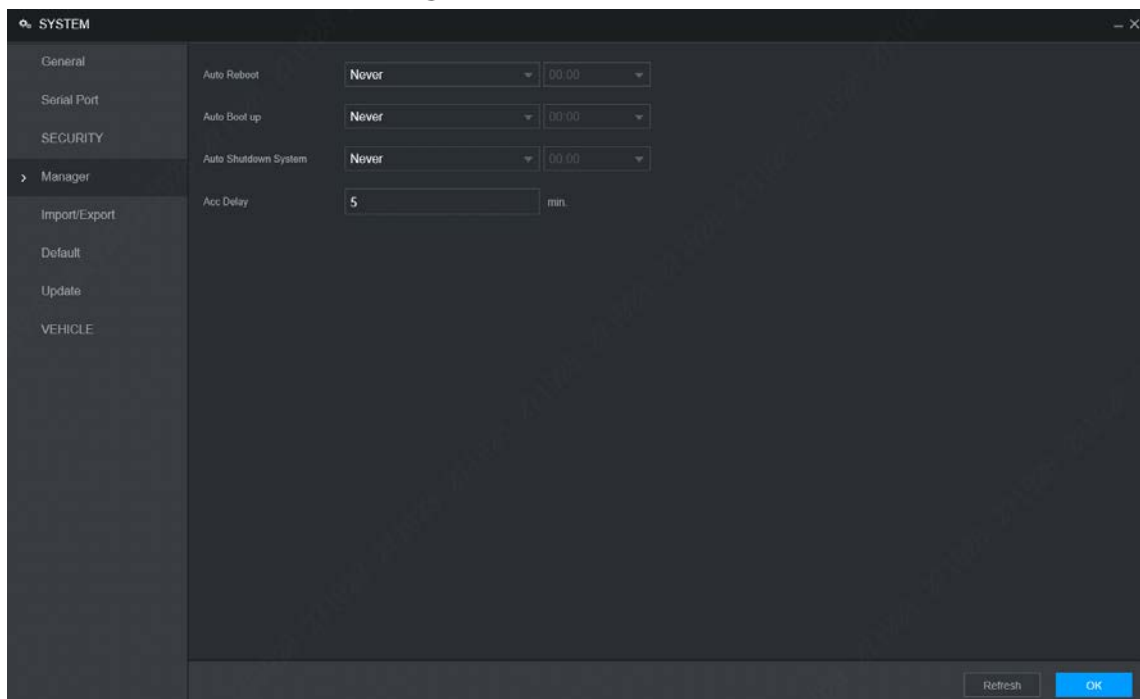

Step 2 Select the strategy of auto restart.

- Select **Never**, and the device will never restart automatically.
- Select **Every Day**, set the device restart time, and the device will restart automatically at that time point.
- Select **Monday** to **Sunday**, set the device restart time, and the device will restart automatically at that time point every week. If **Sunday** and **01:00** are selected, the device will restart automatically at 1:00 every Sunday.

Step 3 Click **OK**.

7.3.2 Auto Boot up

After configuring auto start, the device starts automatically at the scheduled time point. If you turn the vehicle key to ACC before the configured auto start time, the device starts immediately. When the documentation is powered off, the device will shut down as per the scheduled auto delay for shutdown.

Step 1 Select Setting > System > Manager.

The **Manager** interface is displayed.

Step 2 Select the strategy of auto start.

- Select **Never**, and the device will never start automatically.
- Select **Every Day** and set the time. When you turn the vehicle key to ACC before this time point, the device starts immediately.

Step 3 Click **OK**.

7.3.3 Auto Shutdown System

After configuring auto shutdown, the device automatically shuts down according to the ACC power off time and auto boot up setting.

- If you have set the time for auto start, there are two situations when the ACC is powered off: If the system time is between the auto start time and auto shutdown time, the device is turned off at the configured time point. If the system time is before the auto start time or after the auto shutdown time, the device is turned off immediately.
- If the auto booting up is not set, when the ACC is disconnected, the device shuts down at the scheduled time.

Step 1 Select Setting > System > Manager.

The **Manager** interface is displayed, see Figure 7-6.

Step 2 Select the strategy of auto shutdown.

- Select **Never**, and the device will never shut down automatically.
- Select **Every Day** and set the time. The system will shut down as per the ACC power off time and auto start setting.
- Select **Every Day** for **Auto Shutdown**, and then enter the specific time.

Step 3 Click **OK**.

7.3.4 Acc Delay

After configuring delay for auto shutdown, when ACC is disconnected, the device shuts down as per the settings of delay for auto shutdown.



- If you enter a delay value that is not 0, the device automatically shuts down after the preset delay.
- If you enter 0, the device shuts down as per the auto shutdown settings without delay.

Step 1 Select Setting > System > Manager.

The **Manager** interface is displayed, see Figure 7-6.

Step 2 Configure the auto delay for shutdown.

The value ranges from 0 through 65535. The fault value is 5.

Step 3 Click **OK**.

7.4 Backup and Restore

You can back up or restore the web configurations and restore to default settings.

7.4.1 Backing up Configurations

You can back up all the configurations of web.

Step 1 Select Setting > System > Import/Export.

The **Import/Export** interface is displayed, see Figure 7-6.

Figure 7-7 Import/Export

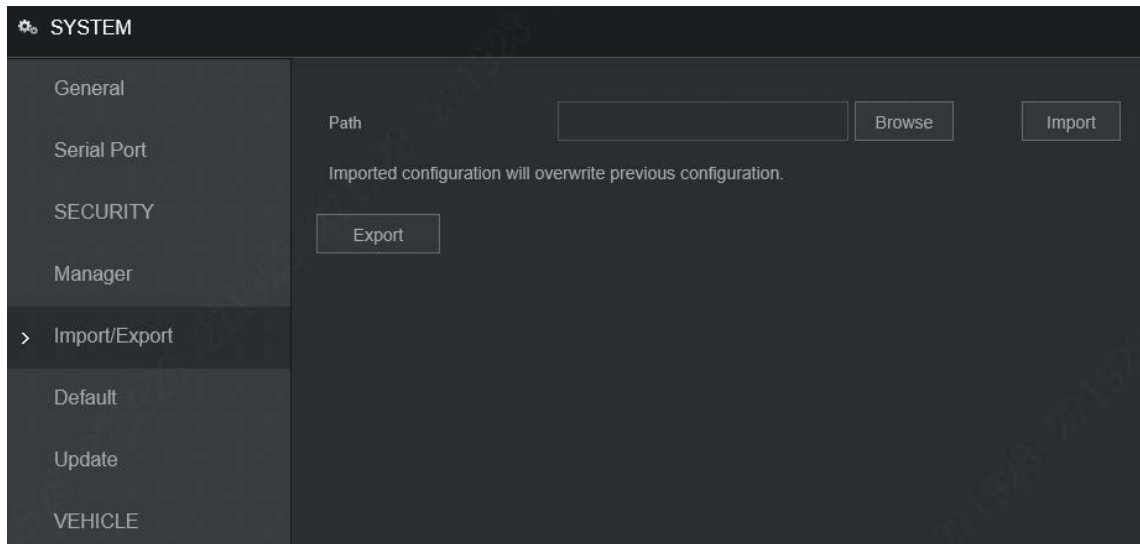

Step 2 Click **Export**, and select the backup path.

The system starts backing up configurations.

7.4.2 Importing Configurations

You can use the backed up configurations to quickly configure the device and restore the device configurations.

Step 1 Select Setting > System > Import/Export.

The **Import/Export** interface is displayed, see Figure 7-8.

Figure 7-8 Import/Export

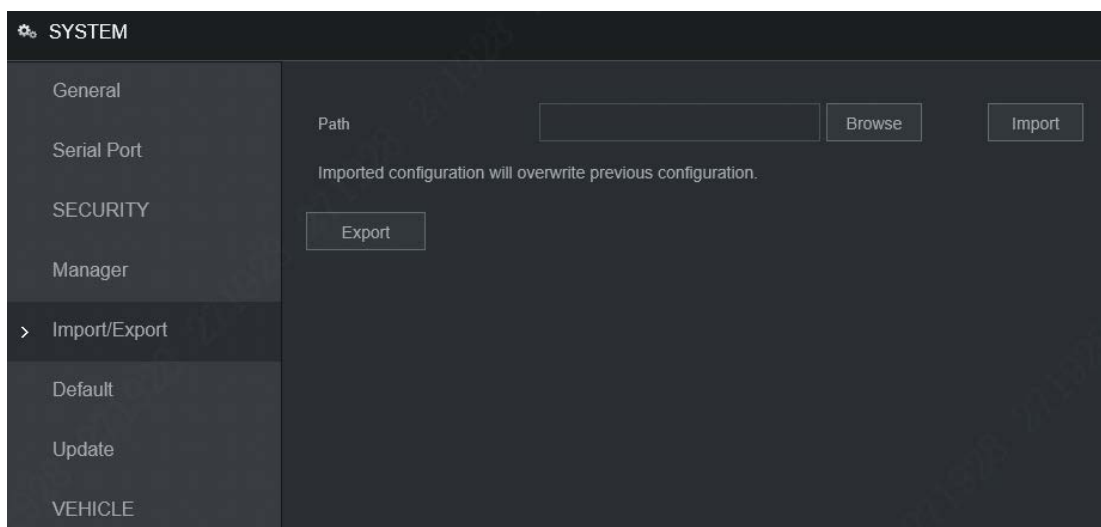

Step 2 Click **Browse**, and then select the backup file you want to import.

Step 3 Click **Import**.

The system pops up the reboot message. Click **OK**, the system starts importing the configurations and reboot the device after importing is completed.

7.4.3 Restoring to Default

You can restore the system to default configurations or the factory default. Only the user with the default & upgrade authorities can do this.



The corresponding functions will be restored to the factory settings, and your current configurations will be lost. Proceed with caution.

Step 1 Select Setting > System > Default.

The **Default** interface is displayed. See Figure 7-9.

Figure 7-9 Default

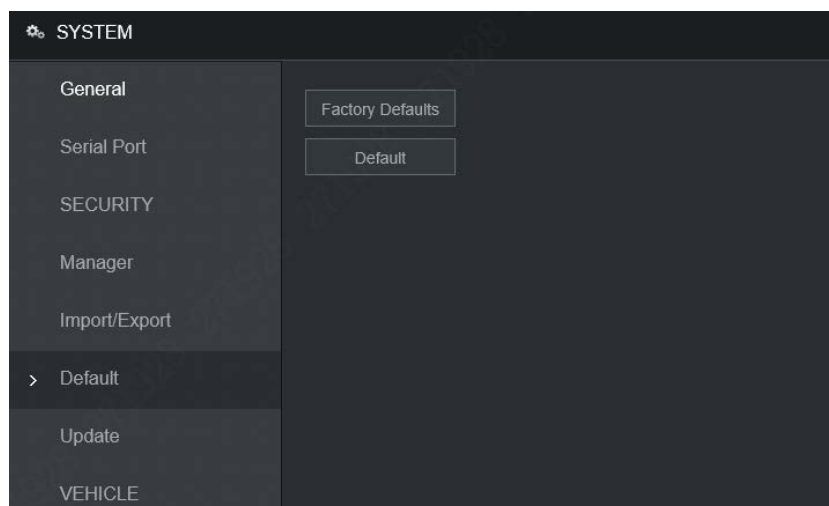

Step 2 Select the check box of the options that you want to restore to the factory default.

- Default: Click **Default**, and the **Reboot** dialog box is popped up. See Figure 7-10. Then click **OK**. All configurations other than user name, password, security questions, device IP, 4G, Wi-Fi are restored to the default configuration of the device.
- Factory Default: Click **Factory Default**, and the **Reboot** dialog box is displayed. See Figure 7-11. Then click **OK**, and the system restarts. After the device is restarted, the system will restore to factory defaults, and the device requires initialization again. Proceed with caution.
- When there is a user operating on the local interface, the factory default settings cannot be performed until the local user log out.

Figure 7-10 Reboot (1)

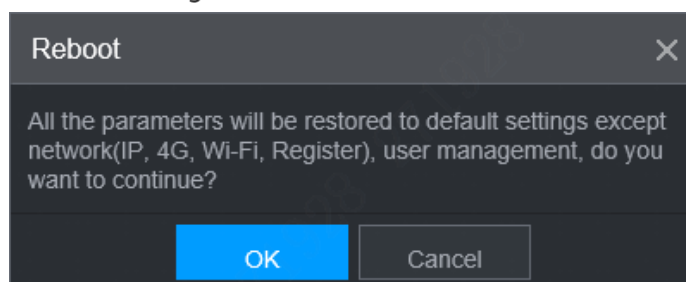
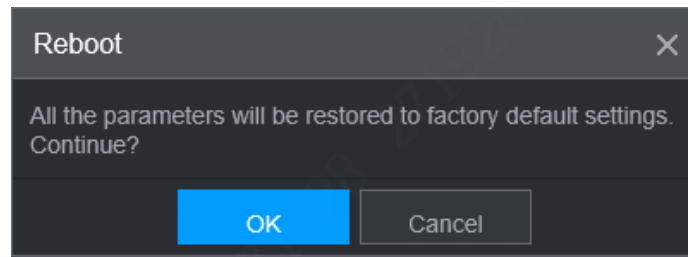

Figure 7-11 Reboot (2)



7.5 Network Sniffer

The packet data can be provided to the developers or engineers to analyze the network usage status.

Prerequisites

The device being captured is connected to an external backup device.

Procedure

Step 1 Select Setting > Info > Packet Sniffer Backup.

The **Packet Sniffer Backup** interface is displayed, see Figure 7-12.

Figure 7-12 Packet Sniffer Backup

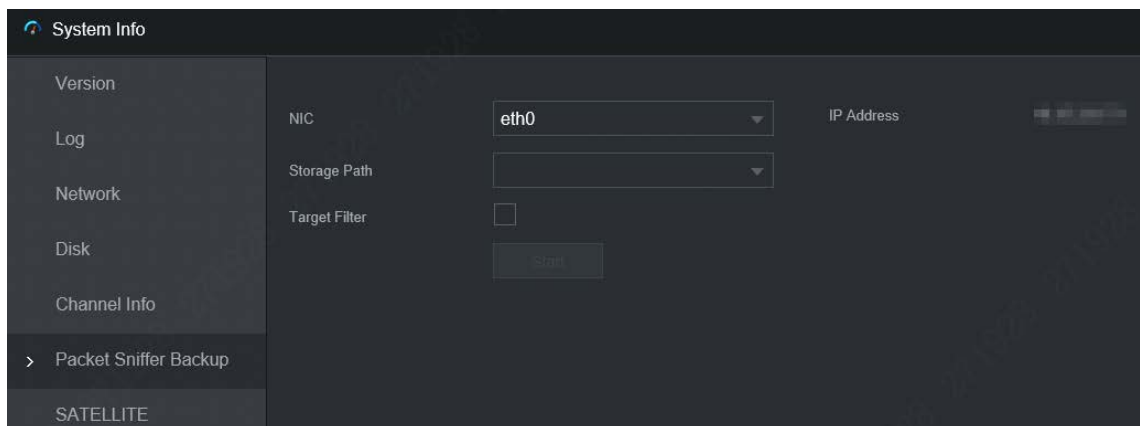

Step 2 Select the Ethernet card and save path.

Step 3 Select the **Target Filter** check box, and then enter the IP address that you want to filter.

Step 4 Click **Start**.

The system starts the sniffer, and the data will be stored to the external backup device.

Step 5 Click **Stop**.

The **Message** dialog box is displayed, see Figure 7-13.

Figure 7-13 Prompt

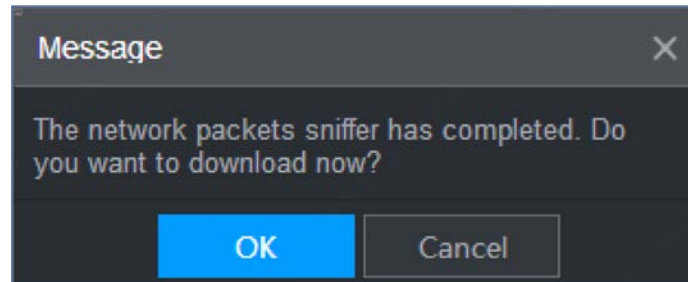

Step 6 Click **OK** or **Cancel** to complete the task.

- Click **OK** to download the files locally, which can be viewed in the storage path; click **Cancel** to stop downloading.
- Click **Cancel** to stop downloading this sniffer file.

8 Logging in to the Device from DSS

Beside from WEB, you can also remotely log in to the device from Digital Surveillance System (DSS)
For details, see the manual of DSS.

Appendix 1 FAQ

If your questions are not solved by following the answers in this document, contact your local customer service or call customer service at headquarters. We will guide you to solve your problems.

1. Q: Disconnect the constant electricity but the device is still working.

A: Possible reasons:

- The UPS setting provides constant power supply to the device when the lithium battery voltage is above 7V.

2. Q: The device gives squeal after start.

A: Possible reasons:

- Connecting to the display and being too close to the camera.
- A single channel interface or a large-image multi-channel interface. The first route of sound comes from a local source.

3. Q: The interface shows that no SIM card is detected.

A: Possible reasons:

- SIM card not inserted.
- Micro SIM card reversely inserted with its notch facing outward. Follow instructions on the label to insert the SIM card.
- SIM card is damaged.

4. Q: DVR cannot boot up properly.

A: Possible reasons:

- The input power is not correct; the input voltage is too low or too high.
- Poor contact in the input power cable or incorrect wiring.
- HDD is damaged or poor contact between the HDD carrier and HDD.
- Main board is damaged.

5. Q: DVR automatically reboots or frequently crashes.

A: Possible reasons:

- Input voltage is unstable or too low
- The device is not properly installed, which result in poor contact between components.
- Poor heat dissipation and too many dusts result in poor working environment for the device.
- Hardware malfunction.

6. Q: Blank screen in a channel of the display.

A: Possible reasons:

- A camera is damaged. Replace the damaged camera.
- The connection wire is damaged. Replace the damaged connection wire.

7. Q: There is no video output for single channel, multiple channels or all channels.

A: Possible reasons:

- Incorrect program. Upgrade to the correct program.
- Image brightness is set as 0. Restore to default settings.
- Video input signal is null or too weak.
- Channel protection (or screen protection) is set.
- Hardware malfunction.

8. Q: Real-time video image is abnormal, such as color and brightness is distorted.

A: There are the following possibilities:

- NTSC and PAL settings are not correct, and the image becomes black and white.

- Device and monitor resistance is not compatible.
 - Video network transmission distance is too far or transmission line signal attenuation is too much.
 - NVR color or brightness settings are not correct.
- 9. Q: I cannot search video record in local playback.**
- A: There are the following possibilities:
- Poor contact between the HDD carrier and HDD.
 - HDD is damaged.
 - Upgraded a program different from the original program file system.
 - The video record is overlapped.
 - The video record is not opened.
- 10. Q: The local video record is blurry.**
- A: Possible reasons:
- The image quality is too low.
 - Program read error, bit data is too small, and there is full of mosaic in the screen. Please firstly try to restart the DVR to solve this problem.
 - HDD Error
 - Hardware malfunction.
- 11. Q: No audio.**
- A: Possible reasons:
- It is not an active speaker.
 - Audio cable is damaged.
 - Hardware malfunction.
- 12. Q: There is audio under monitoring state but no audio under playback state.**
- A: There are the following possibilities:
- Audio function is not enabled.
 - The corresponding channel does not connect to the camera. Playback is not continuous when the screen is blue.
- 13. Q: The time displayed in the video record is wrong.**
- A: Possible reasons:
- Error settings.
 - Poor battery contact or low voltage.
 - Crystal oscillator does not work.
- 14. Q: USB backup error.**
- A: There are the following possibilities:
- Too much data which occupies CPU resources. Please stop recording first and then begin backup.
 - Backup device is not compatible.
 - Backup device is damaged.
 - The backup device features high power and needs separate power supply.
- 15. Q: Alarm does not work.**
- A: Possible reasons:
- Incorrect alarm settings.
 - Incorrect alarm wiring.
 - Incorrect alarm input signal.
 - An alarm device is connected to 2 loops at the same time.

16. Q: Messy channel display.

A: Possible reasons:

- Incorrect selection of camera type. Auto switch is recommended.
- The camera is damaged.

17. Q: Record storage period is not enough.

A: Possible reasons:

- Low camera quality, dirty lens, camera installed against the light, or iris not properly adjusted caused large big rate.
- HDD capacity is not enough.
- The HDD is damaged.

18. Q: No 3G/4G dial-up. No dial-up IP.

A: Possible reasons:

- Check if the SIM card is normal.
- Check if the SIM card is not in service.
- Check if the 3G/4G antenna is connected as intended.
- Check if the 128 G/4 G signals are strong enough.
- Try out with another SIM card.

19. Q: 3G/4G platform is not online.

A: Possible reasons:

- Check if 3G/4G dial-up is normal.
- Check if local active registration is correctly set up.
- Check if the sever terminal is correctly set up.

20. Q: No GPS data.

A: Possible reasons:

- Check if the GPS antenna is connected as intended.
- Make sure the GPS antenna is in a place where signals are not blocked.

21. Q: GPS drifting and produces speed for no reason.

A: Possible reasons:

- Weak GPS signal.

22. Q: Video record is silent.

A: Possible reasons:

- Check if a normal analog camera is connected. Only HDCVI camera with audio input supports audio.

Appendix 2 Storage Capacity Calculation

When the device is installed for the first time, make sure the HDD (or TF card) is installed.

Capacity calculation formula:

Total capacity (M) = Channel quantity × Demand time length (hour) × storage capacity occupied per hour (M/hour)

Recording time calculation formula:

Recording time (hour) =
$$\frac{\text{Total capacity (M)}}{\text{Storage capacity occupied per hour (M/hour)} \times \text{Channel quantity}}$$

The device adopts H.264/H.265 compression technology, which features a large dynamic range. Therefore, when calculating HDD capacity, you should accord to the bit rate to evaluate the file size generated per hour from each channel.

Appendix 3 Cybersecurity Recommendations

The necessary measures to ensure the basic cyber security of the platform:

1. Use Strong Passwords

Please refer to the following suggestions to set passwords:

- The length should not be less than 8 characters.
- Include at least two types of characters; character types include upper and lower case letters, numbers and symbols.
- Do not contain the account name or the account name in reverse order.
- Do not use continuous characters, such as 123, abc, etc.
- Do not use overlapped characters, such as 111, aaa, etc.

2. Customize the Answer to the Security Question

The security question setting should ensure the difference of answers, choose different questions and customize different answers (all questions are prohibited from being set to the same answer) to reduce the risk of security question being guessed or cracked.

Recommendation measures to enhance platform cyber security:

1. Enable Account Binding IP/MAC

It is recommended to enable the account binding IP/MAC mechanism, and configure the IP/MAC of the terminal where the commonly used client is located as a whitelist to further improve access security.

2. Change Password Regularly

We suggest that you change passwords regularly to reduce the risk of being guessed or cracked.

3. Turn On Account Lock Mechanism

The account lock function is enabled by default at the factory, and it is recommended to keep it on to protect the security of your account. After the attacker has failed multiple password attempts, the corresponding account and source IP will be locked.

4. Reasonable Allocation of Accounts and Permissions

According to business and management needs, reasonably add new users, and reasonably allocate a minimum set of permissions for them.

5. Close Non-essential Services and Restrict the Open Form of Essential Services

If not needed, it is recommended to turn off NetBIOS (port 137, 138, 139), SMB (port 445), remote desktop (port 3389) and other services under Windows, and Telnet (port 23) and SSH (port 22) under Linux. At the same time, close the database port to the outside or only open to a specific IP address, such as MySQL (port 3306), to reduce the risks faced by the platform.

6. Patch the Operating System/Third Party Components

It is recommended to regularly detect security vulnerabilities in the operating system and third-party components, and apply official patches in time.

7. Security Audit

- Check online users: It is recommended to check online users irregularly to identify whether there are illegal users logging in.
- View the platform log: By viewing the log, you can get the IP information of the attempt to log in to the platform and the key operation information of the logged-in user.

8. The Establishment of a Secure Network Environment

In order to better protect the security of the platform and reduce cyber security risks, it is recommended that:

- Follow the principle of minimization, restrict the ports that the platform maps externally by firewalls or routers, and only map ports that are necessary for services.
- Based on actual network requirements, separate networks: if there is no communication requirement between the two subnets, it is recommended to use VLAN, gatekeeper, etc. to divide the network to achieve the effect of network isolation.